

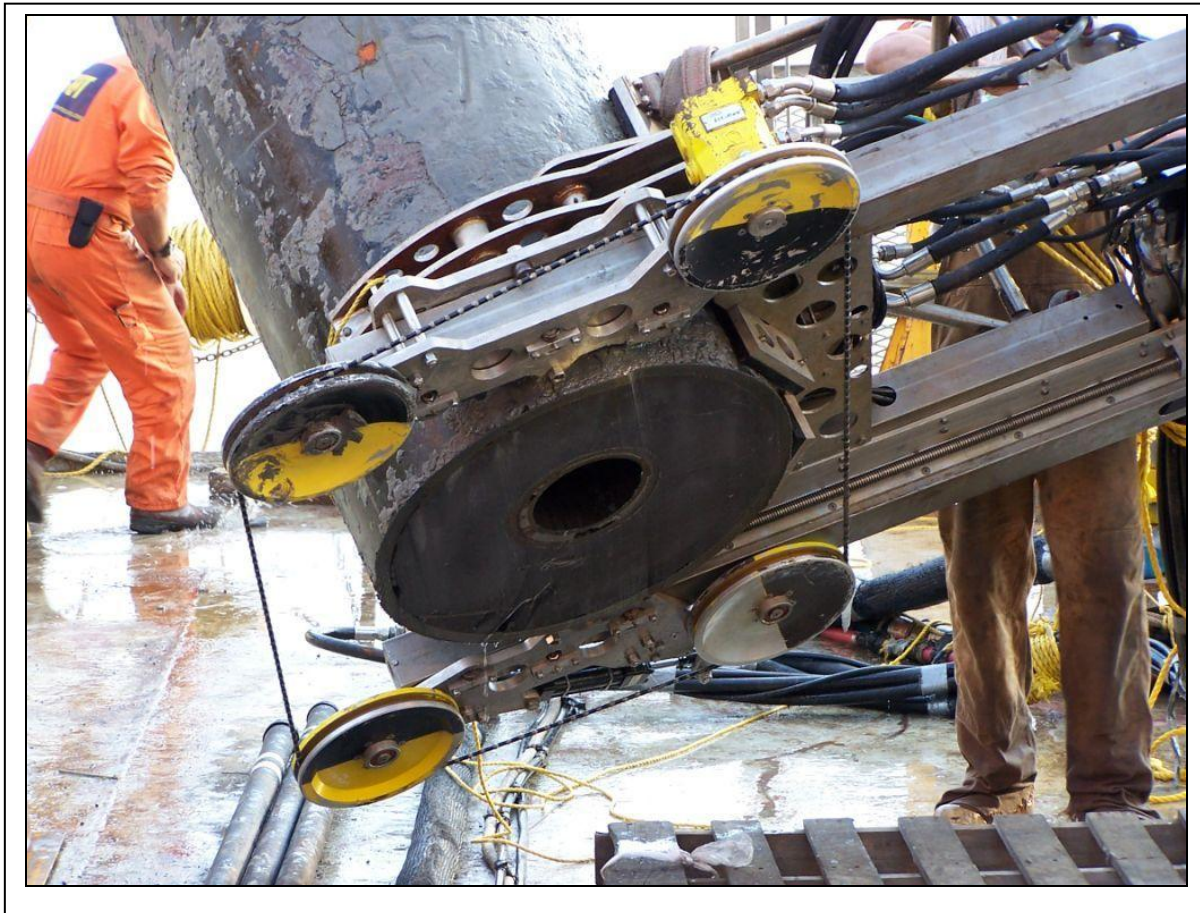

Cutting Underwater Technologies Ltd
Representative of TS Tecnospacec
Diamond Wire Cutting Technology



Cutting Underwater Technologies Ltd.

Representative of TS Tecnospacec Diamond Wire Cutting Technology

E-Brochure





Cutting Underwater Technologies Ltd
Representative of TS Tecnospacec
Diamond Wire Cutting Technology



COMPANY OVERVIEW & BACKGROUND

Group Profile

TS Tecnospacec was established in Genoa, Italy, in 1981. Its role, to perform advanced research and development projects leading to the deployment and operation of the new technologies for deep-water engineering projects offering support to the offshore and maritime industries.

Diamond Wire Cutting System

In 1991 Tecnospacec, developed the Diamond Wire Cutting System, a high efficiency, patented system, for the cutting of underwater structures using a specially designed Diamond Wire

Thereafter the CUT (Cutting Underwater Technologies) Group of companies, headquartered in Aberdeen, Scotland, was established by Tecnospacec in 1999. Their mission? To offer a range of services that utilised the advanced DWCS (Diamond Wire Cutting System(s)) developed by Tecnospacec. The primary focus for the new technologies was the platform and pipeline decommissioning markets, initially in the North Sea and later into other key oil producing regions around the world. Expansion has seen the diamond wire systems used on:

- Platform Topsides,
- Onshore Pipelines,
- Refining and other industrial applications
- The Nuclear Industry



The System has been extensively used in cutting jacket legs, thereby allowing offshore structures to be removed, subsea pipelines and conductors have also been severed with maximum efficiency and unsurpassed cost competitiveness.

Once positioned on to the structure that is to be cut, the DWCM uses its own hydraulic clamping system to lock itself in place. All operational functions of the DCWM can be controlled either from the surface using a stand alone Hydraulic Power Unit, Control Panel, Umbilical and Spooler or by utilising a WROV's own hydraulic supply. It can be seen therefore that the system is 100% safe for the operator who controls the wire speed, working pressures and flow rates required for maximum cutting efficiency remote from the actual cutting operation.

CUT now boast substantial experience in this key technology within the Offshore Structure Management & Abandonment sectors. Such has been the success of the patented DWC technology available through CUT that the group now has operational bases in Norway, Singapore, Brazil and the United States.

The Group markets and operate the Tecnospacec Diamond Wire Cutting System worldwide and is actively involved in major international decommissioning projects both on and offshore.



Mono-pile Cut
(Agip, Mediterranean)



Reinforced Concrete Slab
9.52m x 3.14m x 2.57m 2



DWC in Progress

CUT HQ, Aberdeen Science and Energy Park, Claymore Drive, Bridge of Don, Aberdeen. AB23 8GD. UK
Tel: +44 (0)1224 222950; Fax: +44 (0)1224 826006; E-mail: info@cut-group.com; Web www.cut-group.com

VAT Reg No: 743 2799 09 Company No: 197961



Cutting Underwater Technologies Ltd
Representative of TS Tecnospacec
Diamond Wire Cutting Technology



TECHNICAL DETAILS

Diamond Wire Cutting Machines (DWCM)

A Diamond Wire Cutting Machine (DWCM) is a hydraulically activated machine used for cutting subsea and topside structures, pipelines and other industry plant or equipment of any size, shape or composition.

To achieve the cutting action a continuous loop of diamond wire is mounted on a number of pulleys, one or more being driven. Between two of the pulleys there is a large span of wire that performs the cutting as it comes into contact with the target material and remains so until the cut is complete. The basic DWCM hydraulic functions include the wire drive, wire feed, clamp and wire tensioners.

36" DWCM

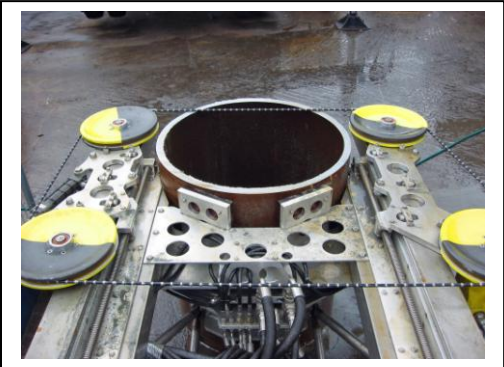

Control Methods Safety = Remotely

The DWCS is capable of carrying out its mission at a specific location under the given environmental conditions while positioning, installation and recovery, checking and wedging operations are possible either with diver or ROV assistance when used underwater. Alternatively when used either on the platform or on land a specially trained CUT operator would position (using a crane or other lifting assistance) the DWCM into position. All units are lightweight and easy to handle.

DWCM's Modes of Operation

Surface Powered Mode

Surface Powered DWCM is connected to the Hydraulic Power Unit using a multi-core umbilical in the region of 40 to 200 metres long. This then connects, on the surface, to the control panel through which the operator controls the wire speed, working pressures and flow rate for optimum cutting efficiency.

ROV Mode

The ROV Controlled DWCM is connected either directly or indirectly through a short umbilical, with all the hydraulic functions being powered through the work class ROV's (WROV) onboard systems. Cutting functions are still controlled topside whilst a WROV or observation ROV can be used to monitor the cut progress.

Stand Alone

The Stand Alone system was developed for deep cutting operations where the WROV cannot provide enough hydraulic power. The DWCM & camera functions are controlled by a laptop computer via a purely electrical umbilical, Designed using proven ROV power and control technology. The Stand Alone system facilitates cutting at greater depths than previously achieved with the larger DWCM's.



HPU



Spooler & Umbilical



Hyd. Control Unit



Cutting Underwater Technologies Ltd
Representative of TS Tecnospacec
Diamond Wire Cutting Technology



APPLICATIONS

CUT UK and our daughter companies have gained extensive experience around the globe on many different cutting applications. This expertise is detailed in the following "Track record" section. However, the following listing gives some understanding of our capabilities

Multistring Tubulars



Diamond wire is the only technology currently capable of cutting through a damaged non-grouted multistring with a cut clean enough to allow for re-insertion.

The diamond wire is ideal for cutting straight, bent, twisted, grouted or non-grouted multistrings quickly and effectively with no doubt as to the final result.

Pipelines

Pipelines with any kind of external or internal protection, such as concrete, PVC, Epoxy, etc. can be cut in a single operation and at any depth.

Large Size Structure Cutting

The Diamond Wire Cutting System suits both offshore and onshore applications. By using standard machines, orbital cutters or custom-built DWCM's, virtually any structure can be cut to the exact requirements of the client either as a single piece or into sections for easier handling.

Platform Removal

Unlike other cutting systems, once the wire has passed through the leg, there is no doubt as to the completion of the cut. The client is always 100% guaranteed that upon lifting, the Jacket will be free.

This feature, together with a vast number of machines available, ranging from 10" to 150" cutting capacity, make Diamond Wire the ideal solution for decommissioning by minimizing the cost of vessels and equipment.



Other Materials

Diamond Wire Cutting is not just restricted to offshore activities and for cutting through steel. Solutions can be provided onshore as well and for other materials, for example:-

In 1996, at the Federal Tait Paper mill, Inveruire, Scotland, a reinforced concrete block of 9.52 by 3.14 by 2.57 meters was successfully cut.

In 2000, at an Onyx and Marble, quarry in France. Large section cutting and dressing with approximate dimensions of upper 7 by 7 meters; lower 8 X 8 meters; height 19.5 meters.

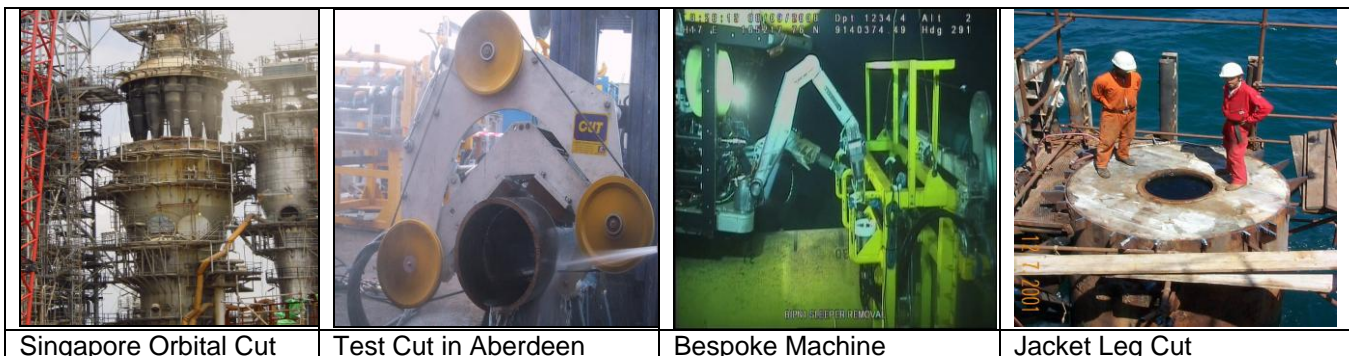



Cutting Underwater Technologies Ltd
Representative of TS Tecnospacec
Diamond Wire Cutting Technology



Integrated Engineering Support Services

The building, and opening, of CUT's new, Aberdeen, HQ facility has consolidated all of CUT UK's operations under one roof. The additional space has also facilitated a significant growth in CUT's support services and manpower resources.

Recent major decommissioning projects in the North Sea:

- Frigg DP1 (Jacket piece small abandonment)
- Frigg DP2 (Piles & legs cut prior to re-float)
- Frigg DP2 (Jacket piece small reduction)
- N.W. Hutton (80+ Jacket cuts)
- MCP01 (20+ Topside cuts)
- Frigg QP (Jacket piece small reduction)
- Ekofisk (Numerous cuts on various infrastructure removals)



CUT's New Aberdeen
Headquarters

have demonstrated beyond doubt that CUT's integrated services approach offers the client full support during both the engineering and offshore phases of any project. Thus each cut can be pre-engineered prior to mobilisation allowing all parties to be fully aware of the workscope and thereby minimising "surprises" once offshore.

CAD Capability

CUT have the capability, in-house, to offer a full C.A.D. service which allows accessibility checks, configuration drawings, project storyboards and machine compatibility tests to be carried out as part of the engineering support services offered to the client.

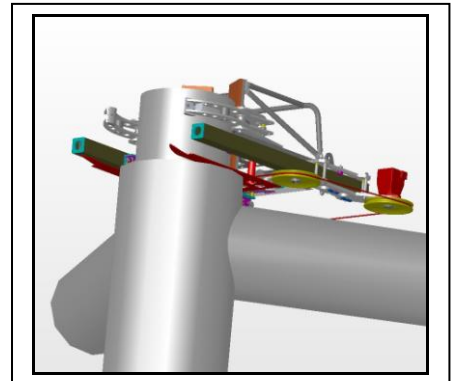

Technological Developments

60 – 120 Modular DWCM

CUT's capability to engineer solutions to client requests has again been demonstrated during these projects which have seen the introduction of the 'Modular' DWCM concept and the unique capability to offer the innovative option of a 'Castellated Cut'. The cutting capacity of the Modular DWCM can be altered by changing the centre section of the machine thereby allowing a reduction in deck space requirements, greater, more flexible machine configuration and overall project cost savings



The Modular DWCM can cut 60-84 inches in one configuration and 85-121 inches in the second. It is equipped for/with:

- Dual mode castellated or Z cut
- Active Wedging system
- Diamond Wire severing cutter
- Real time read-outs of feed and tension values
- Front and rear TV cameras
- Umbilical hot stab for ALL functions
- ROV docking interface
- Surface LCD monitor for TV and read-outs
- Deployment Basket



Cutting Underwater Technologies Ltd
Representative of TS Tecnospacec
Diamond Wire Cutting Technology



Developed from CUT's earlier innovation the 'Z' or 'Step' cut Castellated Cutting was developed to allow a severed target to retain a high degree of residual strength such that it will maintain stability during bad weather or delays in performing the actual lift.



Test Cut - Onshore



Severed Jacket Leg Onboard Crane Barge

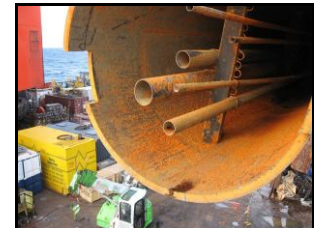

Completed Cut - Offshore

Another advantage of the 'Castellated Cutting' technique may be that some, if not all of the major cuts can take place without the need to have a crane barge in attendance thus offering potential for large cost savings.

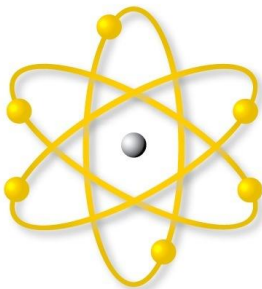

CUT NUCLEAR

CUT Nuclear

A major milestone in CUT's development was the formation, in 2009, of CUT Nuclear aimed, as the name suggests, squarely at the global nuclear decommissioning market.

In 2008 Tecnospacec developed a new generation of 100% electrically driven and powered DWCM's for cutting Steam Dryers structures (stainless steel) in contaminated pools. In May 2009 the first commercial cut of a Steam Dryer at an American BWR Nuclear Utility was completed using this technology.

As a follow on from this successful project, CUT Nuclear has been awarded the contract for removal of 1 (with 2 Optional) Dryer(s) in Sweden during 2010 and 2011

The new challenges that Tecnospacec and CUT will face will mean that new thinking, new designs and new techniques will be needed to develop the specialist technology and service capability required to succeed in this market.

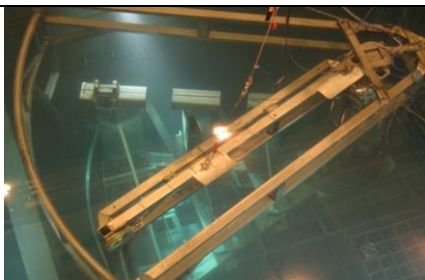

Electrical DWCM in position prior to commencement of cut

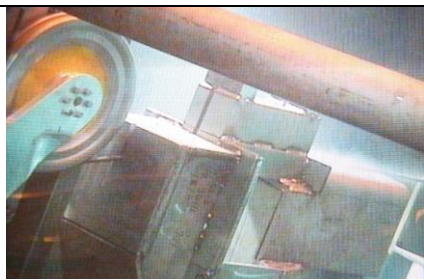

Cutting in Progress



Electrical Control Cabinets



DWCS RECORD (June 2011)



Key data Summary

Projects	613
ROV assisted	214
Diver assisted	267
Platform removed	91
Platform Removals Back-up	6
Pipeline Removals	125
Pipeline Repairs	66
Contingency Projects	31
Number of Cuts	3696
Cuts of pipelines	957
Cuts of Multistring	562
Cuts of chains	54
Cuts of flexible and special pipelines	351
Cuts of drill strings	52
Cuts of risers/Guide posts/Pipes	532
Cuts of various items	146
Fat/Demo Tests	286
Cuts Offshore	3410
Cuts deeper than 1000m water depth	213
Cut surfaces and Time	
Steel (sqdm)	58515
Coating/Concrete (sqdm)	393617
Total cutting time (hours)	8123
Deepest EPRS Shell USA	- 1,600m
Deepest CUT Production Petrobras Brazil sealines	- 1,568m
Deepest CUT Exploration Chevron Texaco 8" Drill pipe Nigeria	- 2,434 m





DWCS RECORD (June 2011)



Projects details

Year	Assisted	Water	Customer	Project
	by	Depth (m)	Location	Details
2011	Surface	4	Stemat/Visser & Smit Hanab/Netherlands/Fetsy L	Power Cable Cut (8" OD)
2011	ROV	110	Maersk Oil/Bibby Offshore/North Sea/Gryphon FPSO/Bibby Topaz/Lochranza LN2/LW	Lochranza LN2/LW/Cutting of Various Flexible Risers (6",10")
2011	Surface	19	Exxon Mobil/Aceryg France/Angola/ Aceryg Antares	OSO-RE Project/ Several Pipelines Cuts (12",16",21")
2011	ROV	800	SBM Offshore/Offshore Brazil	4,13" Studless Chain Cut
2011	ROV	400	Subsea7/Cutting Underwater Technologies premises/Ålgård	Skarv Flowlines/Contingency
2011	ROV	90,5	Oceaneering International/North Sea/Ensco 100	4,13" Multicore lifting strop Cuts
2011	ROV	2,5	EMAS AMC/GOM/Pt. Fourchon/Boa Sub C.	Flexible Riser Cutting
2011	ROV	19 - 120	Maersk Oil/North Sea/Lochranza LN2/LW/Seabed Worker	Cutting of Several Umbilical & Risers (1 OD5",86 OD6",3 OD8",3 OD9",14 OD10")
2011	Diver	28,95	Apache/Cameron/High Island A323"A"/DB Swing Thompson	High Island A323"A" Platform Removal
2011	Diver	28,95-70	OSFI/Apache/Cameron/High Island A323"A"/DB Swing Thompson	High Island A323"A" Platform Removal
2011	--	--	Shell/Scan Bilt/Palau Bukom Refinery	Cutting of Pipeline in Sump
2011	ROV	70	Conoco Philips/DOF Subsea Norway AS/North Sea/Ekofisk EDDA/Skandi Inspector	Tommeliten Riser Bundle Cut
2011	ROV	300	Statoil/Subsea7 Norway/North Sea/Troll Platform	Troll Platform Clamp Cut
2011	--	--	BP/Subsea7/Cutting Underwater Technologies premises/Ålgård	Valhall Re- Development Project/Trial Cuts
2011	--	--	Island Offshore/Mongstad base	Togi Hub Cutting/Trial Cuts
2011	--	--	Subsea7/Cutting Underwater Technologies premises/Ålgård	Skarv Flowlines/Cut Trial
2011	ROV	22,86	Energy XXI/South Timbalier/BOAZ/GOM	South Timbalier 21 & 85 Conductor Cutting
2011	Diver	6-21,336	PetroQuest/Bisso Marine/GoM/Brazzos446-L/Superior Future	Brazzos446 Conductor Cutting
2011	Diver	22,86	PetroQuest/Bisso Marine/GoM/Brazzos446-2 SE/4	Brazzos446 Caisson Cutting
2011	Diver	40	Total/SMIT Subsea Europe/North Sea/Southern Dutch Sector/ELF petroland B.V K5B/ETD Protea	Flexible Pipeline Cut
2011	Diver	11	Cantrica/Sub Aqua Diving Services/Ljmuiden/Inner Dowsing wind farm/MPI Resolution	Wind Farm Pile Cuts
2011	ROV	280	Shell Norge/Island Offshore/North Sea/Draugen Field-Mou Island Constructor/ Island Constructor	Cutting of 10" inch Flexible
2011	ROV	145	Statoil/Technip Norge AS/North Sea/Statfjord C Field	Statfjord C Riser Replacement
2011	ROV	773-1010	Total/Aceryg France SA/Offshore West Africa	Block 17 Pazflor Field
2011	Diver	8	Chevron/HydrodiveOffshore/Offshore Nigeria/Chevron controlled Field	Cutting of 24" Pipeline
2011	--	--	BG/Wood Group Engineering/North Sea UK OCS/Everest Platform	Two Pad Ears Cut
2011	Diver	13,4	Energy XXI/ BOAZ / GOM	South Timbalier Conductor Cutting 30" and 24"
2011	Diver	13,716	Petroquest/Energy XXI/ Port Fourchon, LA/ GOM	South Timbalier 27 #4 Conductor Cutting
2011	Diver	21,336	PetroQuest Energy/Seamar Davis/Brazzos446/GOM	Conductor Cutting
2010	ROV	23-81	Hereema Marine Contractors/Conoco Philips/Ekofisk/Thialf	Ekow/Ekor/Ekop Removal/2010 Campaign





DWCS RECORD (June 2011)



Year	Assisted	Water	Customer	Project
	by	Depth (m)	Location	Details
2010	Diver	23	Apache/Cameron LA/WC 226/Kylie	Caisson Removal
2010	Diver	13-33	Apache/International Offshore/West Delta 71/IOS 800	Platform Removal
2010	ROV	80-100	Acergy/Taurt and Ha'py field/Offshore Egypt	Contingency Piles Cutting
2010	--	--	Apache Corporation/Texas/MI 633-C/L/B	Caisson Cutting
2010	Diver	45	Chevron/Technip Oceania/Gulf of Thailand/Benchamas field	Cut of Shackles and Chain Links
2010	Diver	30,5	Dynamic Offshore/ Matagorda Island/ GoM/ DSV Seadiver	Conductors Removal
2010	Diver	67	Jab Energy Solutions/ Vermillion 309/ GoM/ DB Kallop	Pile Cutting
2010	Diver	4,5 - 9	JAB Energy Solutions/ Merit Energy Co./ GoM/ Cameron	Caisson and Pile Cutting
2010	Diver	20	Veolia/ Petrobras America Inc./ Galveston/ Gom/ Viking Poseidon	Guide Post Support Base
2010	Diver	45	Jab Energy Solutions/ Petro Quest/ BA 22/ GoM/ Arapaho	BA 22 Removal
2010	Diver	30,5	Diamond Services/ ERT/ South M.35/GoM/ D.85	Multistring Conductor
Year	Assisted	Water	Customer	Project
	by	Depth (m)	Location	Details
2010	Diver	58	JAB Energy Solutions/Mississippi Canyon 486/Black Diver III	Platform Removal
2010	--	--	Shell Eastern Petroleum Ltd./Palau Bukom	Cutting of Reactor and Regenerator
2010	ROV	300	Technip AS/Asgard Gas Flowline and Spreadre Cut/North Sea/Normand Piobear	Gas Flowline and Spreader Subsea Cutting
2010	ROV	79	DOF Subsea/ConocoPhillips/north Sea/Skandi Skolten	DOF Pipeline Removal
2010	Diver	70	Deep Ocean/Conoco Phillips/Ekofisk/Normand Flower	ALBF Pile and Bracing Cut
2010	ROV	2185	Technip UK / Petrobras/ Santo Basin/ Solitaire	Petrobras Contingency Pipeline Cutting
2010	Diver	46	Acergy France/ Total/ Block 17 - Offshore Angola	Gas Export Pipeline Project Contingency
2010	Diver	73	Subsea 7/ Exxon Mobil/ Rockwater2/ Malaysia	Cutting of 11" Pipelines
2010	Diver	30-40	J.A.B./Merit Energy Company/Cherokee/Vermillion/GoM	Platform Removal
2010	Diver	21-50	Subsea 7/Total/DSV Seven Pelicav/North Sea	MCP01 Vertical Truss and Riser Removal
2010	Diver	52	O.S.F.I./St Mary's/Vermillion/GoM/D.B. Kallop	3 Jacket Leg Removal
2010	--	--	Subsea 7/ BP/ North Sea	Skarv Contingency - Trail Cuts
2010	ROV	350	Technip/Shell/Shell Corrib Field/North Sea	Contingency Offshore Ireland Shell Corrib Field
2010	--	--	Subsea 7/D.O.F. Management/Valhal Field/ MSV Geosund	Cutting of Valhall Flank
2010	Diver	76	Subsea 7/Conoco Philips/Eldisk Field/Seven Pelican	Cutting of a 24" Flowline
2010	ROV	100	SaipemSonsub/Transocean/Myanmar/Drilling Rig Actinia	Cutting of a Conductor
2010	Diver	120	Acergy/Chevron/Captain Field/North Sea/Acergy Osprey	B21 Tree Hub Repair
2010	--	--	Subsea 7/c/o AS Premises	Cutting in Contingency of Skarv Flowlines
2010	ROV	330	Offtech/Bluewhale/CNOCC/Shenzen/Huafa	Cutting of gooseneck
2010	ROV	764	Subsea7/Hess/Ceiba Central Cluster/Bourbon Peridot	Umbilical Cut
2010	Diver	75	Claxton Engineering/Talisman/Acergy Discovery/North Sea	Talisman Riser Cut
2010	ROV	300	Fugro Rovtech/Irish Sea	Casing Cut
2010	Diver	30	Subsea7/Shell/North Sea/Toisa Polaris	Indefatigable Pipelines Removal
2010	Diver	75	Deep Ocean/Conoco Phillips/Norwegian Sector/Edda Fonn	Ekor Riser Preparation
2010	ROV	500	Subsea 7/North Sea/Subsea Viking	Drill Collar and String Cut
2010	Diver	110	Bluewhale/CNOOC/Offshore China/MVI HUARA	Cutting og Flexi and Umbilical





DWCS RECORD (June 2011)



Year	Assisted by	Water Depth (m)	Customer Location	Project Details
2010	Diver	31	Hallin Marine UK/Canyon/North Sea/Northern Canyon	30" Casing Cutting
2010	ROV	550	Doris Engineering/Total E & P/Congo/Polar Prince	Anchor Mooring Chain Cut
2009	ROV	320	Offtech/Bluewhale/CNOCC/Shenzen/Huafa	Cutting of gooseneck
2009	Diver	54	Superior Energy/South Timbalier 130/GoM/Normac Clough	Lift Boat Leg Cutting
2009	--	30	Subsea7/Shell/North Sea/Toisa Polaris	Indefadigable Pipelines Removal
2009	ROV	--	Allseas Engeneering BV/South Argentina/Highland Rover	Magellan Strait Pipe Contingency
2009	--	62	Fugro Rovtech/Fugro Saltire/North Sea	20" Pipe Cutting
2009	ROV	125	Subsea 7 Greenwell Base	Guide Post Cutting
2009	--	--	Stress Enginnering/DW Rupe Project/Waller Texas	Pipe Cutting
2009	Diver	23	Diamond Services/IRT/West W 331/D85/GoM	102" Monopole with Multistring Inside
2009	ROV	305	Canyon Offshore/MC194/Normand Commander/GoM	Pipeline Cutting Offshore
2009	--	28	Beryl/Crescent/ST 195 A/Arapaho/GoM	Platform Decomissioning
2009	ROV	1341	ATP/OCD 13198 #4/GoM/Iron Horse	Guide Base Cutting
2009	ROV	305	Canyon Offshore/Shell/MC194/Msv Normand Commander/GoM	Pipe Cutting
2009	--	--	Hallin Marine UK/Canyon/North Sea/Northern Canyon	30" Casing Cutting
2009	ROV	1400	SBM Services/Petrobras/Skandi Fluminense/Brazil	FPSO Capixaba Relocation
2009	--	99	Saipem UK Ltd (Sonsub Division)/Far Samson/S7000	Frigg "QP" Platform Removal
2009	--	--	Saipem UK Ltd (Sonsub Division)	Hire of Over-boarding Fairlead
2009	ROV	500	Doris Engineering/Total E & P/Congo/Polar Prince	Anchor Mooring Chain Cut
2009	ROV	27	Subsea 7/Conoco Phillips/Ekofisk 2/4 W/North Sea/normand Mjolne	Bracing Cut/VDM Removal
2009	--	380	Technip/Geoholm/North Sea/Norwegian Sector	Super Duplex Pipeline
2009	ROV	107	Statoil Hydro/Island Offshore/Island Vailant/Oseberg Field/Norwegian Sector	Cutting of Wellhead North Housing on Omega Field
2009	--	36	Apache Corporation/VR-284A/GoM/Kestrel	Jacket Leg and Conductor Cutting
2009	Diver	55	Jab Energy Solutions/Nippon Oil Exploration/WC 532/Spartan 208	Platform Removal
2009	Diver	27,5	Apache Corporation/EI GoM/Boaz	Multistring Cutting
2009	Diver	12	Energy XXI/GoM/WC238/Kylie	Caisson Cut
2009	--	30,5	Apache/Aceryg Osprey/GoM/IOS 800	Vermillion Removal
2009	Diver	21	OSFI/William Gas Pipeline/Swing Thompson	Jacket Leg With Pile Cutting
2009	Diver	21,6	Helix Energy Solutions/GoM/Bob - Palmer	Multistring Conductor Cutting
2009	--	61	Jab Energy Solutions/Nippon Oil/Merit Energy/GoM EI 288/DB Cherokee	Multistring Conductor Cutting
2009	ROV	1021	Anadarko/Saipem/Galvestom/Hos Mystique	Jumper with Thermo Coating Cutting
2009	ROV	548	Deep Gulf Energy/Green Canyon/GoM/Q4000	Multistring Conductor Cutting
2009	--	--	Apache Corporation/GoM SS 291 B/Brave	Jacket Leg, Pile, Deck Leg, Multistring Cutting
2009	--	--	HSL Contractor/Shell/Palau Bukom/Singapore	Concrete Structure and Pump Basement
2009	Diver	6,7	Boh Bros Construction/Shaw Group/GoM	Concrete Pile Cutting
2009	--	8	Subsea 7/Curlew/North Sea	Chain Cutting Shell Curlew
2009	--	80	Technip/Conoco Philips/Ekofisk field/Seven Pelican/North Sea	Ekofisk Flowline





DWCS RECORD (June 2011)



Year	Assisted by	Water Depth (m)	Customer Location	Project Details
2009	Diver	25	Conoco Phillips China/Technip SS7/Venturer/China	Mooring Chain Cutting
2009	--	--	Technip AS/ North Sea	North End Gate Protection
2009	--	60	Don/Stine Wellhead/Offshore Denmark/Aceryg Osprey	Nini East Development
2009	Diver	69	Saipem UK/North Sea/Saipem 7000	DP1 Jacket Removal
2009	ROV	26	Hereema Marine Contractors/Conoco Philips/Ekofisk/Thialf	Ekow/Ekor/Ekop Removal
2009	Diver	60	Jab Energy Solutions/nippon Oil Exploration/West Cameron/Cherokee	Caisson Cutting
2009	Diver	1,2	Chet Morris Construction/Palm Energy/West Delta 52/GoM/CM16	Conductor Cutting
2009	Diver	67	BP/Grand Isle 95 A/GoM/Gulmar Falcon	27" Pipeline Citting
2009	ROV	1250	Subsea7/BP/Angola/Bourbon101	Sleeper Cutting
2009	--	--	HSL/FW/Shell/Palau Bukom	Cutting of 4 Concrete Pillars
2009	ROV	24/98	Heerema Marine Contractors BV/BP/Hermod/North Sea	North West Hutton Platform Removal
2009	ROV	375	Subsea7/StatoilHydro/North Sea/Norwegian Sector/Seven Sisters	Receiver Cutting
2009	Diver	5	Aquanos Ltd/Maersk/Offshore Denmark/Finstaship MSV Nordica	Fender Removal
2009	Diver	80	Oceaneering/BP/GoM/SM205/Olympic Intervention IV	Jacket Leg and Brace Cutting
2009	Diver	23	Technip/Wintershall/DSV Skandi Achiever	30" Conductor Cutting
2009	Diver	15	Osiris Diving/Veolia Environmental/New Haven UK/On Shore	Barrette Cutting
2009	ROV	400	Statoil/Trandelag I Filed/North Sea/Island Vanguard	Wellhead Cutting 36"+20"
2009	ROV	21	Heerema Marine Contractors BV/BP/Hermod/North Sea	North West Hutton Platform Removal
2009	Diver	18	Global Offshore/Exxon Mobil/Offshore Nigeria/Hercules Black Jack	24" Pipeline Cutting - Nigeria
2009	Diver	22	Saudi Aramco/J. MacDermott Saudi Arabia/Offshore Saudi Arabia/DB16	Cutting Of a Free Riser
2009	--	--	Anadarko/Saipem/Galveston/HOS MYSTIQUE	Jumper with Thermo Coating Cutting
2009	ROV	0,5/80	Aker Solution/Total/Aker Storde/North Sea/Side Barge 19	DP2 Size Reduction
2009	Diver	27	Micoperi Marine Contractor s.r.l./Egypt Offshore/Adams Nomad	22" Pipeline Cut
2009	--	--	Heerema Marine Contractors BV/North Sea	North West Hutton Platform Removal
2008	--	--	Heerema Marine Contractors BV/North Sea	North West Hutton Platform Removal
2008	Diver	40	Dulam Internation/Statoil/Offshore Iran/Seamac Princess	Pipeline Cutting Offshore Iran
2008	ROV	35	OFSI/BP/West Delta Field/DB Swinging Thompson	Jacket Leg and Diagonal Member Cutting
2008	ROV	0,5/50	Aker Solution/Total/Aker Storde/North Sea/Side Barge 19	DP2 Size Reduction
2008	Diver	45	Aceryg/Half Dan/Aceryg Discovery	20" Pipeline cutting
2008	ROV	210	Technip Norge AS/Island Constructor/north Sea Norwegian Sector	30" Kvitebjorn Pipeline Repair Project
2008	ROV	85	Deep Ocean/CTC/Kittawake Buoy/Volantis	Pile and Ancillary Cutting - Kittawake
2008	ROV	54	Total E&P Norge AS/Saipem/Saipem S7000/North Sea Norwegian Sector	Frigg - DP1 Jacket Removal
2008	ROV	690	Canyon/Allseas/Durgabai Field/Olympic Canyon/India	4"x241,25mm Pipeline Cutting





DWCS RECORD (June 2011)



Year	Assisted by	Water Depth (m)	Customer Location	Project Details
2008	Diver	3/17	S.R.P.T.M./Tangier Harbour/	Concrete Block Removal
2008	ROV	244	W&T Offshore/GoM/Q4000	Multistring Conductor Cutting
2008	Diver	36,5	Merit Energy/JAB Energy Solution/GoM/DSV Tiger	Multistring Conductor Cutting
2008	Diver	28,6	Tetra/Merit/GoM/East Cameron 254/Arapaho	Jacket Leg Cutting
2008	ROV	720	Allseas Engeneering BV/Durgabai Field/India Offshore/Highland Rover	Pipeline Cuts 4"x241.25mm coated
2008	ROV	165,5	Tetra Technologies/Apache/East Break 160/GoM/TigerFish	Multistring Well Conductor Cutting 30"
2008	Diver	36,5	Merit Energy/GoM/DSV Tiger	Multistring Conductor Cutting (16"+10")
2008	Diver	2/5	Bluestream NL/Tyra Oil Field/North Sea/Denmark/Northern River	Tyra Field Fender Structures Cutting
2008	Diver	73,5	ConDive/Vermillion313/Gom/Ocean Commander	Jacket Leg and Conductor Cutting
2008	Diver	39,60	JAB Energy Solutions/OMP/SP 32/LB kaitlyn Eymard/GoM	Multistring Conductor Cutting
2008	Diver	--	JAB Energy Solutions/OMP/Main Pass 75 1/LB kaitlyn Eymard/GoM	48" Caisson with Multiple Well Strings
2008	Diver	7,6	LL&G Constructions/Golden Meadow/GoM	36" pile Cutting
2008	ROV	145	Subsea7/North Sea/Polar Prince	Vigdis Pup piece and Pipeline Cutting
2008	Diver	--	SBM/Hakodate Port/Geosea	Padeye Cut
2008	ROV	520	Transocean/Chevron/Offshore Angola/S701	Damaged Riser Cutting [with buoyancy 43"]
2008	--	25	Fugro Seacore/Pembroke - SW Wales/Deep Diver 1	E 1200 milford Haven Piles Cutting 1300mmODx32mmWT
2008	Diver	2	Blestream NL/Maersk/Tyra West Field/Northen River	(32 and 18" Riser Guard) Tyra Field Strucures Cutting
2008	--	43	Saipem UK/Maersk/Denmark/DSV Bar Protector	20" OD 2" coating Pipeline Cutting (x4)
2008	Diver	18/34	ERT Energy Resource Technologigies/GoM/L/B Ram XII	Caisson Cutting - MI 604 [72" and 48" with 30" multistring]
2008	--	--	Technip/North Sea/Kvitebjorn	30" Export Pipeline
2008	ROV	145	Subsea7/North Sea/Polar Prince	Vigdis Pup piece and Pipeline Cutting
2008	Diver	--	SBM/Hakodate Port/Geosea	Padeye Cut
2008	ROV	520	Transocean/Chevron/Offshore Angola/S701	Damaged Riser Cutting [with buoyancy 43"]
2008	--	25	Fugro Seacore/Pembroke - SW Wales/Deep Diver 1	E 1200 milford Haven Piles Cutting 1300mmODx32mmWT
2008	Diver	2	Blestream NL/Maersk/Tyra West Field/Northen River	(32 and 18" Riser Guard) Tyra Field Strucures Cutting
2008	--	43	Saipem UK/Maersk/Denmark/DSV Bar Protector	20" OD 2" coating Pipeline Cutting (x4)
2008	Diver	18/34	ERT Energy Resource Technologigies/GoM/L/B Ram XII	Caisson Cutting - MI 604 [72" and 48" with 30" multistring]
2008	--	--	Technip/North Sea/Kvitebjorn	30" Export Pipeline
2008	--	--	Subsea7/North Sea/Vigdis	Vigdis WI Pipeline Cutting
2008	ROV	465	Subsea 7/North Sea/Subsea Viking	Foinaven Coated Pipeline Cut 10,75" OD
2008	Diver	145	Acergy UK Ltd/Acergy Osprey/Lyell Field	24"Pile and Follower Pile Cut Lyell Field
2008	--	surface	RGB/Total/North Sea/Dunbar Platform	Dunbar Fender Removal





DWCS RECORD (June 2011)



Year	Assisted by	Water Depth (m)	Customer Location	Project Details
2008	ROV	325	Acergy/Statoil/Asgard	60" Pile Cutting
2008	Diver	24	Saipem Asia SDN BHD/Offshore Taiwan/POE WB2	36" Pipeline Cutting
2008	ROV	130	Single Buoy Moorings/Equatorial Guinea/Normand Installer	4" Flexible Gas Lift Flowline Cut Equatorial Guinea
2008	Diver	10,36	Tetra technologies/Apache/LB Kayd/GoM	Well Intervention/Recovery 48"
2008	ROV	150	Sonsub/PTTEP/Myanmar	Cutting of Wellhead 30"x1"+20"x1"
2008	ROV	70	Apache Corporation/West Delta/Normand Clipper	24" Multistring Conductor Cutting
2007	--	Surface	Drafin Sub/Porto di Genova, Italy	Cutting of 900mmx115mm Pipeline
2007	Diver	125	Hydro Marine Services/Mc Dermott Australia/Angel project	Cutting of 14" and 30" coated Pipelines
2007	Diver	75	Meramid/CUEL/Thailandia	Cutting of a pipeline 10"x1/2"+1"coating OD 12"3/4
2007	Diver	80	Sonsub/Saipem/Thailandia	Cutting of 42"x1"+4" coating pipeline
2007	ROV	300	Bluewhale/CNOOC/China	Cutting 13,5" of risers (Coflexip)
2007	Diver	10,36	Tetra technologies/Apache/LB Kayd/GoM	Well Intervention/Recovery
2007	Diver	--	Besix Kier JV/Milford Haven/Jetty	Cutting of concrete pile 20"
2007	ROV	630	Canyon Offshore/Olympic Triton/Green Canyon	9,6" ROV Umbilical cutting
2007	ROV	1280	Trendsetter Engineering/Exxon Mobile/Ocean Intervention2/Mississippi Canyon	Mica Pig Tail Pipe Cutting
2007	Diver	115	Fugro/RovTech Limited/Transocean Prospect	13 3/8" Casing Cutting Transocean Cutting
2007	Diver	49	Con-Dive/LLC/GoM/Ocean Commander	Jacket Leg and Conductor Cutting
2007	Diver	24,3	Apache Corp./West Delta 75 H/DB "Cherokee"	Jacket Leg Cutting Job
2007	Diver	75	Subsea7/Conoco Phillips/Eldfisk Field/DSV Pelican	24" Pipeline Cutting
2007	Diver	1,2/3,9	Apache/GoM/DB "Arapaho"	Jacket Leg Cutting
2007	ROV	1478	Exxon Mobile/Trendsetter Engineering/Gom/NOR "Tigerfish"	Mica Pig Tail Pipe Cutting
2007	ROV	254/286	Technip/Statoil/Asgard field/CSO Constructor	Asgard J-101 repair
2007	Diver	18,3 / 78,6	Heerema/Conoco Phillips/North Sea/Hermod Crane Barge	Ekofisk CAT 1 Bridges, Flares and Tripod Removal 2007
2007	ROV	300	Subsea7/Statoil/Asgard Field Mid Norway/Skandi Bergen	Asgard Reeled Pipe Installation
2007	Diver	210	Tetra Technologies/Gulf of Mexico/M.V.Cherokee/	Jacket Leg and Conductor Cutting
2007	ROV	212	Apache/Global Divers/Grand Isle Block 82A/Sea Line	Cut Conductor
2007	Diver	13,1	Energy XXI/GoM/L-B "Kaitlyn Eymard"	Multistring conductor cutting
2007	Diver	55	Chevron/Global Divers&Marine/Gom/MSV Pioneer	Conductor Cutting
2007	ROV	610	Helix/Canyon Offshore/GoM/Intrepid	ROV Umbilical cutting
2007	Diver	28	Apache Corporation / GoM / DB Arapaho	20" Multistring well conductor cutting
2007	Diver	33,5	Energy Resources Technology, Inc./ GoM / LB Ram 12	Multistring well conductor cutting
2007	Diver	23	NCG Services / Dragon Oil / Caspian Sea / Bogatir 3	Jacket Removal
2007	--	surface	Acergy SA / Globestar Nigeria Ltd / Mobile Nigeria/ Acergy Orion	16" OSO RD Pipeline Repair Project
2007	ROV	2000	Subsea 7 Brasil/Petrobras/Niteroi/	Flexible Pipe Contingency 6,5"x1,5" and 10"x2"
2007	Diver	26-87	Apache/Tetra Technologies/GoM/Tetra Arapaho	54.5" Jacket Leg and 20"- 24" Pile Cutting





DWCS RECORD (June 2011)



Year	Assisted by	Water Depth (m)	Customer Location	Project Details
2007	Diver	21,5	Chevron/GoM/Boa Deep C	39" Jacket Leg with 16" Pile Cutting
2007	ROV	60	Dong Energy AS/North Sea Danish Sector/Siem Danis	10"OD WI Pipeine Cutting
2007	ROV	100	Aker Marine Contractor/Total/North Sea	Frigg Cessation
2007	Diver	22,8	Apache/Tetra/GoM/Maersk Achiever	Well Conductor Cutting
2007	Diver	30	Apache Corporation/GoM/DSV Dancer	Conductor Cutting
2007	Diver	52 – 75	Wild Well/Apache Corporation/Gulf of Mexico/Normand Clipper	Multistring Well Cutting
2007	Diver	33	Energy Resources Technology, Inc.	Multistring Well Cutting
2007	ROV	640	Canyon Offshore/	Dropped 26" Tendon
2007	Diver	35,6	Chevron/Gulf of Mexico/Swing Thompson	39"Jacket Leg Cutting
2007	Diver	--	Chevron/Gulf of Mexico/DB1	39"1/2 Multistring Conductor Cutting
2007	ROV	125	Subsea 7/Norsk Hydro/Oseberg/Edda Fjord	36" riser cutting
2007	ROV	1829	BP/Mississippi Canyon 778/Thunderhorse/ GoM	Pipeline and Chain Cutting
2007	ROV	54,8	Pioneer Natural Resources/East Cameron 322/Rem Commander	Jacked Leg and Conductor Cutting
2007	ROV	54	BlueStream NL/Denmark/Ensco 71	Buestream 10"
2007	Diver	+2	RBG Ltd/Petrofac/North Sea/Northern Producer	36" OD Pipeline Cut
2007	Diver	40	Hydrodive Nigeria/Addax Petroleum/Nigeria/Barge Victory J316	Cutting of damaged 12" and 30" pipeline
2007	Diver	40	Gassco/Subsea 7/H7/Aceryg Osprey/Toisa Polaris	36" Pipeline Cutting with 50" cutter
2007	Diver	80	Hyundai	Cutting of a 42"x1"+4" concrete coat. Pipeline
2007	ROV	682/831	Daewoo/Sonsub Pty Ltd/Myanmar	Cutting of a 13"3/8 x 13,1mm Riser
2007	ROV	60	Petronas/Swiber Marine/Kuantan Malaysia	6"Abu Cluster Pipeline Cutting For Repair
2007	ROV	127-153	PTTEP/Sonsub Pty Ltd/Zawtika1A/Doo Sung	Cutting of wellhead
2007	Diver	30,5	Apache Corporation/Tetra Technologies/Ship Shoal 193B	Apache Multistring Well Cutting
2007	Diver	37	Samson/Vermillion217A/Rem Commander	Jacket Leg Cutting
2007	Diver	41	Amerada Hess/Wild Well/Briton Sound	Multistring Conductor Cutting
2007	ROV	--	CNR International UK Ltd / North Sea	Cuttin Drill Pipe 5,5" Odx25mm wt
2007	Diver	30 – 60	BP / Saipem Mediterranean Services / Red Sea	16" to 20" Subsea Pipelines Cutting
2007	ROV	2500	Shell / I Tech-Subsea 7 / Egypt	7,5" Drill String Cut
2007	Diver	85 / 150	Statoil / Sobsea 7 JV / North Sea	30" & 42" Pipe Cutting – Sleiper Tie in Subsea 7
2006	Diver	23	Energy XXI/L/B Audrey/GoM	30" Multistring conductor cutting
2006	Diver	9-36,5	Newfield/Toisa Proteus/GoM	39" (x10), 34" (x7), 33" (x2), 30" (x3), 26" (x10), 24" (x5) Multistring conductors cutting
2006	ROV	145	CNR International/Columbia E/Transocean Prospect	5,5" Drill string cutting (x2)
2006	Diver	5,4	Express Energy Service/Dominion WC 225 Well No. 6/Superior Freedom/GoM	48" Multistring conductors cutting (x5)
2006	--	surface	SRC Refinery/Singapore	72" (x2)+ 38"(x8) + 34" (x4) + 21" (x4) c/w refractory mesh Cyclones cutting
2006	ROV	63	Chevron/Wiggins Tide/Angola	16" Riser cutting (2)





DWCS RECORD (June 2011)



Year	Assisted by	Water Depth (m)	Customer Location	Project Details
2006	Diver	3-6	Herbosh-Kiere Marine Contractors/Kirkwall/MC Ails Orkney	Piles cutting OD 1020mm (x2) + side U channels (x2)
2006	ROV	340	Statoil/Technip Offshore Norge AS/Normand Progress/N.Sea - Norway	4,5" Drillstring cutting (x21)
2006	Diver	3-10	Statoil/Amundsen Diving AS/MS Scuba/N.Sea - Norway	1200 mm OD GRP Pipeline cutting (x31)
2006	ROV	500	BP/PGS Production AS/Foinaven West Shetland/M/V Olympic Hercules	111mm Dia Stud less Chain contingency
2006	Diver	82	Statoil/Subsea 7-Aceryg JV/Sleipner - Langed N.Sea Norway	Tie-Back Pipeline 30" to 44" OD(x10)
2006	--	--	BP/PGS Production As/Foinaven/CUT Aberdeen	111mm Dia Chain cutting trial (x1)
2006	Diver	30,5	Newfield Exploration Company/East Cameron 151C Well #C1/Superior Gale/ GoM	36" OD x 1" WT Piles cutting (x2)
2006	ROV	1829	BP/Mississippi Canyon 77, Chloe Candies/GoM	12" (x6) 10" (x1), 8" (x1) specially coated pipelines, 118mm stud less chain (x1)
2006	--	--	BP/Houston	12"(x1), 16"(x1), 18" (x1) Special coat pipelines trial cutting
2006	Diver	30,5	Tetra Technologies/Mustang Island A85/Tetra Arapaho/GoM	MU 85 Platform cutting (Toppling removal) 52" OD 2,250" WT leg piles (x9)
2006	Diver	15	W&T Offshore/L/B Myrtle/GoM	30" Multistring conductors cutting (x5)
2006	Diver	27	Tetra Technologies/MU A16 Platform/D/B Tetra Arapaho/GoM	Jacket legs 52 1/2" OD 1,250" WT 48" OD x 1" WT pile (x8), 30" Multistring conductor
2006	Diver	30,48	Tetra Technologies/Southern Hercules/GoM	30" and 26" Multistring conductors cutting (x15)
2006	Diver	4-18,5	Chevron Texaco /Superior Endeavour/GoM	36", 30", 26" Multistring conductors (x 8)
2006	Diver	9	Cal Dive Intl./Uncle John/CDI Fourchon/GoM	30" Multistring conductor
2006	--	--	TFE/Aker/Port Reval/MCP01/ N. Sea	Radio Tower 5800mmx3500mm steel grout, steel bots M56
2006	ROV	90	Conoco Phillips/Subsea 7/Viking Troll/ N. Sea - Norway	20" OD 0,5" WT pipeline (x2)
2006	Diver	135	Statoil/Subsea 7 Gulfax A Towhead, N. Sea Norway	Gulfax A HE 300B I Beams (x2)
2006	Diver	49-65	Pioneer Natural Resources/Tetra Technologies/DB1/GoM	48" OD x 1,5" WT Leg + 42" OD x 1,5" WT Pile (x2) Jacket
2006	ROV	500	BP/Subsea 7/Foinaven West Shetland/MSV Nordica	10" Water injection Pipeline Repair (273mm x 15,9mm +2,5mm PE external +10mm chromium internal coat- pipeline (x2)
2006	ROV	135	Sonsub UK/ Skinfaks Rimfaks/Normand Cutter/ Offshore Norway	273mm x 15,9mm +50mm coat pipeline chromium 13% (x4)
2006	Diver	55	Phoenix International Inc./Min Pass 185/Kimberly Candles/GoM	30" OD Multistring conductors (x7)
2006	ROV	1824	BP E&P/Canyon/Northern Canyon/GoM	11" x 2"WT+ 7" Coat (x2) + 17" x 1/2" WT (x1) pipelines
2006	Diver	65	Exxon Mobil/Mc Dermott/Tidal Seligi A Field -West Malaysia	18" x 0,372 + 2" concrete coated pipeline (x4)
2006	Diver	120	Mariner Energy/South Marsh Island 66 GoM/S/S Uncle John	30" Multistring conductor





DWCS RECORD (June 2011)



Year	Assisted by	Water Depth (m)	Customer Location	Project Details
2006	Diver	27	Tetra Technologies/Vermillion 412/T. Arapaho/GoM	57" OD x 0,750" WT Leg + 54" OD x 1,250" WT Pile (x4) Platform
2006	Diver	65	Marmeid/CUEL/Mermaid Commander/Offshore Sagkhla- Thailand	16 3/4" x 3/4" + 1 3/8 concrete coated pipeline (x3)
2006	Diver	+5m	Besix Kier JV/Pembrokeshire/surface	Reinforced concrete pile 22" x 3 1/4 " (13)
2006	Diver	170	CNR International/Subsea 7/Lyell N. Sea/Borgsten Dolphin	20" Caisson cutting (x1)
2006	ROV	133	CNR International/Subsea 7/Lyell N. Sea/Borgsten Dolphin	5" Drillstring cutting (x1)
2006	Diver	30,5	Newfield Exploration Company/Superior Gale/ GoM	30" Multistring conductors cutting (x9)
2006	Diver	70	Mariner Energy/Eugene Island 314/ S/S Uncle John/GoM	24" Multistring Conductor (x2)
2006	--	--	Total/Technip/Technip yard Westhill Aberdeen	435,5mm OD, 310mm OD X60 c/w polyprop coating pipeline cut trial (x2)
2006	ROV	--	Statoil/Acergy CUT site Aberdeen	125mm chain link cutting test (x1) - Contingency contract
2006	ROV	--	Langeled - Statoil/Acergy site Aberdeen	44" x 1" +3" Reinforced Concrete Coat Langeled pipeline cutting trial (x1)
2006	--	--	Saipem/Sonsub/Houston Base	48" OD x 1/2" WT trial pipe cutting (x1)
2006	Diver	90	Subsea 7/ Rockwater 1- N. Sea	219,1 mm OD x 23,8 (x3), 219,1mm OD x 23,8mm WT + 55mm coat (x4), 168,3 OD x 11mm WT (x2) pipelines
2006	--	--	Sonsub UK/ CUT UK Base Aberdeen	10 3/4" OD pipe 13% chromium cut test (x1)
2006	ROV	640	Chevron/Saipem America/ M/V Normand Cutter-Green Canyon 237 GoM	26" OD x 0,880" WT Typhoon Tendon (x1)
2006	ROV	140	Subsea 7/N. Sea/ Sedco 704	Contingency 3" dia chain link
2006	Diver	+3m	Herbosh-Kiere Marine Contractors/Hail ken Point, Milford Haven- SW Wales/Skerchi/Samson	30" Reinforced concrete piles (x35), Steel Pile (x1)
2006	Diver	10-50	Horizon Offshore/Cal Dive Intl./Main Pass 289/Atlantic Horizon SAT XI	Platform Leg 39" OD 3" WT (x8) pipeline 24" x 1" + 2,5" Coat (x3)
2006	--	--	BP Exploration & production/Canyon Off./Canyon Base	OCGS 15607, GC 743 - 2 Sections wellhead guide base
2006	ROV	1000	Global Ind. Off./EEK/Green Canyon 298 GoM/D/B Emily Candies	4,5" + polyurethane +0,2" coat pipeline (x2)
2005	--	--	BP Exploration & production/Franks Yard/Lafayette, LA - USA	Multistring Conductor 36" x 1,5" + 24" x 0,625" + 18 5/8" x 0,5" + 14" x 0,75" Trial Cut
2005	Diver	80	Apache/Tetra Applied Technologies Main Pass 296-A-Gom/DB Swing Thompson	Platform legs 46" x 1 1/4" + 42" x 5/8"(x8)
2005	ROV	1829	BP/Oeaneering Intl./M/V Edison Choust/Mississippi Canyon 777 GoM	Thunderhorse 7,6" Shackle (1 FAT + 1 Offshore)
2005	ROV	1064	Shell/Transocean/Oeaneering/Intl/Deepwater Nautilus/Green Canyon 434 GoM	21" Riser (x2); 6" 1/2" line (x10); 3 1/2" line (2); 4 1/2" line (x2)
2005	Diver	140	Shell Penguins/Subsea 7/Toisa Polaris/N. Sea	8" OD c/w plastic coat (x3); 10" OD c/w plastic coat (x6); 24" OD c/w plastic coat (x7) pipelines





DWCS RECORD (June 2011)



Year	Assisted by	Water Depth (m)	Customer Location	Project Details
2005	Diver	130	Total/All Seas/Stolt/Seaway Osprey/Block 3/15 – N.Sea	Pipe in pipe: 510mm OD + Ixoflex sleeve+477mm OD with PU resin + 381mm OD pipeline (x1); 444.5mm OD + Shrink Sleeve+381mm OD pipeline (x2)
2005	ROV	70	Murphy Oil/Oceaneering/Ocean Epoch Offshore Malaysia	30" Wellhead contingency
2005	Diver	--	Total/Stolt Offshore/MCP01 Truss Removal	FAT Tests of tailored machines on reinforced concrete sample
2005	Diver	50	Petronas Carigali Vietnam/Barabada Mc Dermott/DB30 Offshore Vietnam	10 3/4" ND + 65mm coated pipeline (x8)
2005	Diver	10	Gulf Oil/Seawind Diving/Wellard Barge/Petroplus Jetty 1 Milford haven S/W Wales	610mm OD + 245 or 250 mm OD + 140 mm OD grouted piles (x5); 705 to 765 mm OD piles steel piles (x7)
2005	Diver	70	Anglo-Suisse Offshore Partners LLC/West Delta 117D/Gom	36"+16"+13 3/8"+7" Multistring conductors (x5)
2005	ROV	2000	PGS/Fugro Survey/Schihallion/Olympic Hercules N. Sea	5 1/2" OD Spiral Wire (x2)
2005	Diver	98	PGS/Subsea 7/MCP01/Pelican N. Sea	813mm OD pipeline (x4)
2005	Diver	61	St. Mary Land & Exploration Co./West Cameron 542/Rig Todco 253/GoM	Wellhead Recovery 36"+20"+13 3/8" + 9 5/8 Multistring
2005	Diver	30	New Field Oil Co./Tiburun Divers/Eugene Island 182/M/V Joe G. Jr./GoM	30" +20"+13 3/8" + 9 5/8" Multistring conductor (x5)
2005	Diver	3-10	BP/Fairweather Pacific Inc/PRC-421/Carpenteria CA USA	36" +24" Multistring (x2)
2005	Diver	77	Anadarko Petroleum/Eugene Island 296 A/Cal Diver II/GoM	45 3/4" jacket legs (3)
2005	Diver	33	Forrest Oil/Cal Dive Inc./Main Pass 98/GoM/L/B Myrtle	72" OD Caisson (2) + 30" Multistring Conductor (1)
2005	Diver	36	Brunei Shell Petroleum/Master Tech/Offshore Brunei/Imam Armada	8" OD x 9.5 mm WT pipeline (x2)
2005	RO V	100	Total/Aker M.C./Botnica/Frigg DP2 North Sea Norway	1422 mm OD Main + 1067 mm OD inner piles - corner leg (x1) onshore and offshore test cut
2005	Diver	--	Total/Aker M.C./Frigg DP2 Onshore FAT	1422 mm OD Main + 1067 mm OD inner piles - corner leg (x1) onshore 550 ton compression test cut
2005	Diver	3	Mærsk Oil and Gas AS/Stolt Offshore/Seaway Osprey N. Sea	813 mm OD Bumper Bar Support (x3)
2005	Diver	--	Shell Pulau Bukum (Refinery)/Singapore	48" OD Tower cutting
2005	ROV	14	MISC / Talisman/Subsea 7/DSV Rockwater 2/Malaysia	92mm chain link
2005	ROV	370	Statoil/Stolt Offshore/Seaway Eagle/Norway	Guide post 8,6" OD 2,36" WT + 20mm wire
2005	ROV	1000	CNOOC/Global Industries/Offshore Shenzen (PRC)	12" coated pipeline, 20" coated pipeline contingency
2005	Diver	23	Murphy Oil/Bisso Marine/Ship Shoal 167-GoM	Caisson 72" + 48"+ 30"+ 16" + 10 3/4 OD
2005	ROV	1664	Unocal/Oceaneering/Ocean Baroness/Hivaman 1	13 3/8" Casing
2005	Diver	40	Total/Skandi Patagonia/Tierra del Fuego	22" OD Pipeline cutting
2005	Diver	--	Rainbow Mechanical/Abu Dhabi	Haseloy C heat Exchanger pipes cutting (x3)
2005	Diver	18	Edison/Marine Consulting/M/B AD3/P.to San Giorgio M4 Adriatic Sea	26" (12), 24" (4) OD piles, 30" OD Multistring Conductors (4)





DWCS RECORD (June 2011)



Year	Assisted by	Water Depth (m)	Customer Location	Project Details
2005	ROV	--	Texaco/Oceaneering/ Offshore Nigeria	8" Drillstring contingency
2005	ROV	1173	Unocal/Oceaneering/Ocean Baroness/Indonesia	13 3/8" Casing
2005	ROV	1108	Unocal/Oceaneering/Ocean Baroness/Indonesia	13 3/8" Casing
2005	ROV	400	ENI/Oceaneering/DSV Island Frontier/Kristiansund Norway	21" Riser+ Choke and Kill Lines +Buoyancy = 39" OD
2005	Diver	--	CHIYODA/Shell Pulau Bukum (Refinery)/Singapore	10m OD Cracking Tower with refractory mesh
2004	Diver	190	ENI/Sonsub/Bar Protector-Normand Cutter/Bahr Essalam Libya	12" (1), 22" (5), 10" (3) OD Pipeline cutting
2004	Diver	10	ENI/Marine Consulting/MV Pigafetta-Palinuro 2/Gela- Italy	12" OD + polyethylene + expanded foam + concrete coating pipeline cutting (17)
2004	Diver	88	PMS/Subsea 7/N. Sea UK/Mayo/Tamasah NW	12"(3), 14"(2), 6" (3), 32" (2), 36" (1) OD Pipelines cutting
2004	Diver	126	Total/Subsea 7/Toisa Polaris/Frigg	32" NCP01 SPUR Line c/w f4,8mm fibreglass and 47,6 concrete coatings
2004	ROV	127	Statoil/Subsea 7/Toisa Polaris/Norway	6"x 7,5mm + 6mm coating (x12) Pipeline
2004	Diver	10-12	AGIP/Marine Consulting/Palinuro II/Gela	34" x 0,5" WT + 192mm Coating pipeline (x16)
2004	ROV	449	Unocal/Ocean Baroness/Sadewa 4 - Indonesia	13 3/8"X 0.75 Casing
2004	ROV	866	Oceaneering/Grand Canyon/Ocean Interventer/GoM	22" Multistring well 22"x3/4" + 5"x1" (x1)
2004	--	--	BSP Brunei/Kuala Belait	Multistring conductor Demo test 30"x1"+13"5/8x0,5"+9"5/8x0,5"+7"x0,5"
2004	--	--	Woodside/Clough Engineering/CUT Base Singapore	12"3/4x5/8" + 36 mm coating pipeline FAT (x1)
2004	--	--	BP/Sonsub US Workshop	4" OD x 1" pipeline FAT (x1)
2004	--	--	TS Base/Workshop Genova	Test trials for new generation wires and DWCM's (pipelines range 12" to 20" - 4 cuts)
2004	ROV	1448	Oceaneering/Ocean America/GoM	36"x1"1/8+20"x3"+5"1/8 x1" Multistring well
2004	Diver	78	Conoco Phillips/Subsea 7/Ekofisk - Growth/Seaway Osprey/N. Sea Norway	20"X 0.75" +60mm coat pipeline (x4)
2004	Diver	45	Talisman/Subsea7/Beatrice B/Pelican/N.Sea pipeline tie ins	6" x1" +1" coat pipeline tie-ins (x4)
2004	Diver	33	W&T Offshore/Eugene Island EI 384 E/GoM	Multistring conductor 30"+9"5/8+7" (x15)
2004	ROV	2434	Chevron Texaco/Oceaneering/DW Discovery	8" x 2,5" WT drill string
2004	ROV	330	Subsea 7/N. Sea Norway	16" Pipeline cutting (x2)
2004	Diver	92	Shell/Subsea 7/Toisa Polaris/N. Sea	Z spool cutting 219mm x 13.2mm (x3)
2004	Diver	71,5	Tetra S P 89 A/Caldiver II/GoM	Platform legs 91"x 2" + 84" x2",5 (x8)
2004	Diver	59	Chevron Texaco/American Constitution/GoM	WC 564 Severing Project 74,5" OD Leg with 5 x 16" Multistring conductors (x1)
2004	ROV	1642	Unocal/Oceaneering/Ocean Baroness/Rang Gas 7	16" OD casing (x1)
2004	ROV	74	BP/Oceaneering/N. Sea Global Artic IV	8" x 1" WT pipeline cutting (x2)
2004	--	--	Stazione Marittima Spa/Genova Harbour	Cutting of mooring bollard
2004	Diver	46	Marathon/Oceaneering/S. Pass 89 A/Ocean Project	Leg A2 53" (+48"+36"piles), Leg B1 51,25" (+48"+24"piles), 20" OD multistring
2004	Diver	26	Perenco/Cameroon KBC1/Gulf Fleet	30" OD Conductor (x1)





DWCS RECORD (June 2011)



Year	Assisted by	Water Depth (m)	Customer Location	Project Details
2004	ROV	1012	Shell/Stolt Offshore/Bonga field /Seaway Polaris	15.27" OD + 12,28" Pipe in Pipe with 4mm plastic coat
2004	ROV	1751	Unocal/Oceaneering/Ocean Baroness	16" OD casing (x1)
2004	--	--	BP/Oceaneering/Eugene Island 322/Onshore tests	48"OD (x1), 53" OD + 46" OD (x1) stepped cut
2004	ROV/Diver	27-35	BP/Oceaneering/Eugene Island 322/Ocean Service.- Intervention	Production and Drilling Jackets (2) topping/Diagonals 24" OD (x17), Legs 51 1/4" + Piles 48" OD (x8, 4 stepped), Sump Caisson 36" OD
2004	ROV	1829	Unocal/Oceaneering/Ocean Baroness/Gula 3	16" OD casing (x1)
2004	ROV	137	Agip/Thales/Sea Explorer - Bredford Dolphin/Offshore Libya	30" OD WT 1" Piles (x3) - 36" OD x 1" WT (x15)
2004	ROV	579	Torch Offshore/GoM/Midnight Wrangler	4.5" OD Pipeline cutting (x3)
2004	--	--	Shell Pulau Bukum (Refinery)/Singapore	Cracking tower orbital cutting test (x2)
2004	ROV	1913	BHP/Oceaneering/GoM/Glomar Explorer	22" casing and 5" Drill pipe
2004	ROV	1005 -719	Japan Oil/Oceaneering/Atsumi-A1-Wjapan/Jobes Resolution	5" Drill string cutting (x2)
2004	Diver	17	Saipem/Sonsub/Offshore Sicily/Sentinel - Castoro 6	37,5" OD Pipeline cutting (x107)
2004	ROV	1338	Heerema/Oceaneering/GC 645/Bolder	6,5" mooring chain (x2)
2004	Diver	110	Hyundai/Hallin Marine/Ulsan/Hyundai 423	17.5" + 3" coat pipeline (x3)
2003	ROV	Tank	Heerema/Oceaneering/Morgan City	6.5" Chain cutting test
2003	ROV	1024	All Seas/Oceaneering/Pioneer/Gulf of Mexico	10.75" OD pipeline (x27)
2003	--	--	BP/Wood Group/Aberdeen - NW Hutton Top side decommissioning	Test trial on 36" OD pipe with wires, beams, square profiles etc.(x2)
2003	Diver	13	Frazer Diving/Pagerungan/Clementine	23" OD pipeline (x2)
2003	Diver	80	Walter O&G/Stolt/Am. Constitution/West Delta 111	84" OD WT 2,5" Caisson
2003	--	14	SBC Subbottomcutter final Trial/Ulsteinvik Norway	36" OD WT 11mm pile cutting - 2,6m below seabed soil
2003	ROV	1846	BP/Transocean/Oceaneering/Discover Enterprise Mississippi Canyon 778 G.o.M.	6,5" (x17) + 3,5" (x6) +6" (x10)+ 21" (x5) Marine Riser recovery project
2003	Diver	121	Woodside/Technip/N. Mankin/Trunkline /Venturer	30" + 2" Coated Pipeline (x3)
2003	--	14	SBC Subbottomcutter final Trial/Ulsteinvik Norway	36" OD WT 11mm pile cutting - 2,6m below seabed soil
2003	ROV	300	Torch Offshore/Garden Bank 240/GoM/Midnight Wrangle	3,5" coiled tubing (x5), 4,5" Coiled tubing (x9), 3,5" pipe (x4), 4" Umbilical twin armour, thermoplastic(x3)
2003	ROV	200	Shell UK/Draugen/Seaway Osprey	18" Inconel Bolt - Back up
2003	Diver	18	Shell Nigeria/Adamac/Kye/DB Dolphin Port Arcourt	41"+ 36"+ 30"+ 3" Legs (x3)
2003	Diver	109	Unocal/Stolt/Vermilion 410/Seaway Defender	60" Leg (x2), 48" Pile (x3), 30" multistring (x2)
2003	ROV	350	Amerada Hess/Stolt Offshore/Seaway Kestel GoM	8" + 2" plastic coated pipeline
2003	Diver	5	Army Corp of Eng. /Kokosing/Barge RST C/S 009	Reinforced concrete 26" jetty piles (x29)
2003	ROV	76	Phillips/Subsea 7/Ekofisk/Botnica	24" Coated pipeline (x4)
2003	ROV	350	N. Hydro/Technip-Coflexip/Fram West/Geobay	20" Pipeline (x6)





DWCS RECORD (June 2011)



Year	Assisted by	Water Depth (m)	Customer Location	Project Details
2003	Diver	110	Shell/Claymore/Rockwater 1	14,5" Coated pipeline (x4)
2003	Diver	85	BP/Subsea 7/Machar/Rockwater 1	30" multistring conductor
2003	Diver	65	TotalFinaElf/Stolt Offshore/DLB 801Eugene Island	259 A Eugene Island Platform removal Back-up
2003	--	--	TotalFinaElf/Stolt Offshore	TFE Platform removal FAT (x2) (42"+36" OD Pipes)
2003	Diver	24	Diamond Services/TS & B/ Huber/USA	72" and 48" OD Multistrings (x1)
2003	Diver	23	Unocal/Marsh Island/ RAM II/USA	30" OD (x1) and 24" OD (x1) Multistrings
2003	Diver	17	AGIP/RANA/ASSOSEI/Civitanova Marche	36"+20" casings (x1)
2003	ROV	1830	Unocal/Oceaneering/Ocean Baroness/Gehem 1	13 3/8" OD casing (x1)
2003	Diver	11	AMGA/CPL Concordia/Genova Harbour	Breakwaters wall reinforced concrete (x5)
2003	Diver	137	Statoil/Subsea 7/DSV Seway Osprey/Grane	30" OD (x2) + 20" OD (x5) pipelines
2003	Diver	137	Statoil/Subsea 7/Seway Osprey/Gulfaks Leak Site	12" ND + 55mm Coating pipeline
2003	ROV	300	Statoil/Stolt Offshore/DPV Viking Poseidon	14" ND+ 55mm coating pipeline (x7)
2003	Diver	103	Texaco/Technip/Captain UTM Orelia	5" OD x 1" wt Pipeline (x2)
2003	ROV	300	Unocal/Oceaneering/Ocean Baroness/Bangau	13 3/8" OD casing (x2)
2003	--	--	Shell valve demo cutting	Inconel Valve block -piping (x3)
2003	--	--	New d. wire & 30" DWCM Superlight demo CUT AS	24" OD wt. 22mm + 50mm concrete coated pipe (x2)
2003	ROV	16	Qatar Gasline/UAE/Seamec 1	16" OD pipeline (x2)
2003	ROV	99	Stolt Offshore/Sanha Field/Angola	30" OD + 20" Multistring Conductor
2003	--	--	New concept diamond wire development project	No. 74 steel samples 100x120x10,2 mm
2003	ROV	900	All Seas/Gulf of Aqaba	36" OD X65 steel coated Pipeline contingency cutting
2003	ROV	1300-1500	Stolt Offshore/GOS Phase 2/Angola/Seaway Polaris	12 3/4" OD PP coated Pipeline contingency cutting
2002	ROV	--	KerrmcGee/J.Ray McDermott Inc.	400T Shackle onshore FAT/demo(x3)
2002	Diver	67	Exxon Mobil/McDermott/TAPIS A/EMPI Platf./DB26	6" ND Pipeline c/w coating (x3)
2002	ROV	240	Halliburton / Gaul Project	Custom DWCM - Removal of ships rudder(2)
2002	ROV	1100	BP/Svinoy well abandonment/Fareo-West Navion	36" Multistring conductor back-up/ Self powered DWCM Stand alone system
2002	ROV	250	Stolt Offshore USA/VIOSCA KNOLL /Seaway Falcon/ROV Sea King	6" Drill string
2002	ROV	224	Stolt Offshore/La Ceiba Field/Seaway Eagle	16" OD Bent Spool piece (x2)
2002	ROV	340	N. Hydro/Subsea 7/ MV BOTNICA	11" OD Pipeline (x31)
2002	ROV	350	N. Hydro/Subsea 7/Heidrum Platform	14" OD Pipeline
2002	Diver	140	Talisman/Subsea 7/Claymore South/Rockwater 1	12,5" ND Pipeline coating FBE 20 (x6)
2002	ROV	95	N. Hydro/Stolt Offshore / Far Saga	Tune Flowline 18"OD polypropylene/nylon coat (x26)
2002	ROV	95	N. Hydro/Subsea 7/ Oseberg Field/NORDICA	Tune Flowline 18"OD polypropylene/nylon coat
2002	ROV	1230	KerrmcGee/J.Ray McDermott/East Breaks/DB50	400T Shackle (x3)





DWCS RECORD (June 2011)



Year	Assisted by	Water Depth (m)	Customer Location	Project Details
2002	ROV	--	Halliburton / Gaul Project	Custom DWCM - Removal of ships rudder/onshore FAT/demo (3)
2002	ROV	300	Statoil/Stolt-Halliburton/Asgard/DSV Viking Poseidon	14"ND 2"wt c/w plastic coat (x4 subsea, x5 on board)
2002	Diver	146	Shell/Halliburton/Brent "C"/MV Toisa Polaris	26" ND 1"WT c/w 2" coating(x3)
2002	Diver	48	BP/Mc Dermott/West Java Arguira Field/Indonesia	12" ND c/w 1 1/2" coating (x2)
2002	ROV	230	Oceaneering /Platform Southern cross MARI B Template Offshore Israel	30" OD x 40mm WT Pile cutting (x2)
2002	ROV	120	N. Hydro TUNE/Halliburton/DSV Nordica	Thune flowline 12" ND(x6)
2002	Diver	22	Exxon Mobil USA/ J-up Carl Norberg/GoM MP74B	96" OD Caisson c/w no. 7x30" OD multistring conductors (x2)
2002	--	--	Exxon Mobil USA	30" OD Pipe cutting test
2002	--	--	Shell USA/Global Manatee	10" + 6" OD c/w foam pipe in pipe surface cutting (x2)
2002	ROV	1728	Murphy/Oceaneering/Ocean Baroness/Bagang Field	5" Drill string cutting
2002	ROV	--	Stolt Offshore/Burullus Offshore Egypt	EPRS for emergency cutting of 4", 10", 20" lines
2002	ROV	--	N. Hydro TUNE/DSND	12" OD Pipeline cutting
2002	ROV	--	All Seas/Australia	EPRS for emergency cutting of 14" pipelaying
2002	ROV	1568	Petrobras/Campos Basin/SCS Seaway Harrier	6" ND Flexible lines (x2)
2002	ROV	300	Statoil/CSO AS/Skandi Inspector/Asgard K101	13" OD Pipeline cutting polypropylene coated (x4)
2002	ROV	118	N. HydroTUNE/Halliburton/Geofjord	Thune flowline 12" ND (x2)
2001	Diver	80	Shell Baram 8 Miri, Malaysia	Wellhead removal, 32"x16"x10"x 7
2001	ROV	1350	BP Amoco/CSO USA - Nile project	EPRS Pipelines 12-16-&18" ND FBE coated
2001	ROV	560	Stolt Offshore/La Ceiba Field/Triton	19,75" c/w polyurethane 46mm thick coat pipeline (x4)
2001	Diver	10	Despe Porto Marghera Harbour	Reinforced concrete pillars T-Wall sections (x6)
2001	--	--	Hallin Marine/Singapore	Super duplex 6,65" OD pipeline demonstration cut
2001	--	--	NKK/Singapore	12" WT 12mm demonstration cut
2001	ROV	106	Ancana/Dominion/Burin -Thebaud S.	WDC Manifold D - 7 & 9" OD pipe special cutting (x3)
2001	ROV	116	N. Hydro/Stolt-Halliburton/MV Geobay	Thune flowline PL1 - PL2 12" ND(x4)
2001	Diver	30	Clyde/UWG/ENSCO 85 P12-C	Well Aband. Progr. - 30" OD Multistring conductor
2001	Diver	35	CPC/Touch/Giant CBK 11, CBK 12, CBK 13	Legs/plies 60"/54" (x4) - 54"/48" OD (x8) - 20"cond. (x4)
2001	Diver	5	TOTAL/KOMARITIM/N.Makam Delta/Awarna	24"OD (x5), 18" OD (x6), 16" OD (x5)
2001	Diver	65	Esso/TL Offshore/Terengganu/DB 26	16" OD pipeline (x3)
2001	Diver	40	BP PT KOMARITIM/N.W. Java Punai	15" OD WT 1/2" + Coat 2" (x4)
2001	ROV	298	Statoil/ Halliburton Subsea/Maxita	12,5" OD Ausgaard Pipeline (x2)
2001	--	3	DEVON/TWATCHMAN SNYDER & BIRD/USA	Devon Energy 72" Multistring jacket legs (x2)
2001	ROV	120	N. Hydro/Stolt-Rockwater/ DSND SUBSEA A/S	Vesterlled 32" OD riser + 32" OD coated pipeline (x8)





DWCS RECORD (June 2011)



Year	Assisted by	Water Depth (m)	Customer Location	Project Details
2001	--	--	N. Hydro/Stolt-Rockwater JV Vesterlled	Vesterlled Pipeline 33" OD Pipe FAT Test
2001	Diver	20	PERENCO/Offshore Cameroon	30" OD Multistring conductor
2001	Diver	13	Agip/Adriatica Sub	2500 mm OD c/w 30" Casing Monopile Flavia (x2)
2001	Diver	13	Agip/Adriatica Sub	1500 mm OD c/w 30" Casing Monopile Fulvia (x2)
2001	Diver	80	Talisman Claymore/Hall-S./Rockwater 1	30" pipeline (x10)
2001	ROV	105	N. Hydro TUNE/DSND/NORDICA	33" Riser (x2)
2001	Diver	25-30	BP "C" PT Komaritim Pgerungam Island	8" gas line cutting (x5)
2001	Diver	80	Statoil Tommeliten/Halliburton/SeawayOsprey	12" (x2), 9" (x3), 6" (x2) Duplex, 30" Ms. conductor
2001	--	--	Statoil Tommelitten/Halliburton Subsea	36,8" OD Pipe (x3) FAT
2001	Diver	18-42	Talisman/Halliburton/ Rockwater 1	Beatrice 16" pipeline cutting (x4)
2001	--	--	Statoil/Halliburton-Stolt Alliance	Tommelitten template 36" piles test
2001	--	--	BP Amoco/CSO USA - Nile project	Pipe in pipe 10,75" + 6,625" OD, FAT (x2)
2001	Diver	80	Halliburton/Subsea/Beatrice/Semi2	16" Rubber coated pipeline (x4)
2001	ROV	120	Elf/CSO/ Lille Frigg 3 XMT	Bolts and sleeves (no 24)
2001	--	--	Elf/CSO Lille Frigg 3 XMT	Bolts and sleeves (no 24) + inn sleeve FAT
2001	Diver	120	Total /CSO/ CSO Apache	16" OD J Tube (x1)
2001	--	--	Total /CSO	Nugget 16" OD J tube cut test (x1)
2001	--	--	Maersk/Aquamarine Danish Sector	30" OD Multistring conductor back-up
2001	ROV	1450	Texaco/Ocean Deepw. Discovery Nigeria	7" OD drill string (x1)
2001	ROV	--	Stolt Offshore	10", 12", 18" Girassol Project pipe-lay contingency
2001	ROV	1100	BP Amoco/CSO USA - Nile project	EPRS Pipe in pipe 10,75" + 6,625 "
2000	Diver	18	PT Komaritim/Indonesia/ISOL Challenger	6" OD Pgerungam pipeline repair cut
2000	Diver	30	Mc Dermott Mumbai High Platform	Risers 12" (x6), 12,75" (x13) 14" (x12,7 Monel)
2000	Diver	90	Texaco UK/CSO/Alliance	24"+16" Pipeline in pipe (x8)
2000	Diver	120	Talisman/CSO/Wellservicer	Water Injection project 8" OD pipe (x9)
2000	ROV	350	Elf NO/Halliburton Subsea/Far Sovereign	16" pipeline cutting (x7)
2000	Diver	30	BHP/DSND/Irish Sea Pioneer	12" pipe (x1)
2000	--	--	Onyx e Marbres Granules SA - S. Beat France	no. 9 Marbles wells
2000	Diver	120	Talisman/CSO/Orelia	8" OD pipe cutting (x3)
2000	Diver	110	Talisman/Halliburton/Toisa Polaris	32" pipeline cutting (x2)
2000	Diver	25	M. Dermott/W. Natuna/DB26	14" (x2) and 22" (x2) Pipelines cutting
2000	Diver	25	M. Dermott/W. Natuna/E Intermac	28" (x1) and 22" (x2) Pipelines cutting
2000	Diver	90	CSO/Durward & Duntless/Orelia	10" pipeline cutting (x4)
2000	Diver	--	CSO/Durward & Duntless/Orelia	8" pipeline cutting test (x1)
2000	ROV	350	Halliburton/SSOL/Shell Draugen/Maxita	16" pipeline cutting (x3)
2000	ROV	650-820	All Seas/Malampaya	Emergency pipeline cutting
2000	ROV	350	Norske Hydro/SCS/Troll	18 5/8" Casing (x6)
2000	ROV	5	Norske Hydro/SCS/Troll	18 5/8" Casing cutting test (x1)
2000	Diver	25	M. Dermott/Singapore/West Natuna	28" Pipeline cutting (x8)
2000	Diver	80	M Dermott/Oceaneering India	16" (x4), 12" 10"(x2) pipe/riser





DWCS RECORD (June 2011)



Year	Assisted by	Water Depth (m)	Customer Location	Project Details
2000	--	--	Halliburton/SSOL/Aberdeen	4" Pipe cutting test (x1)
2000	--	--	Halliburton/SSOL/Aberdeen	16" Pipeline cutting test (x1)
2000	--	--	Halliburton/SSOL/Aberdeen	INCONEL 725 S. Bolt 100mm cut test (x4)
2000	Diver	90	Texaco UK/CSO/ORELIA	24"+16" Pipeline in pipe (x2)
2000	--	--	Texaco UK/CSO/Aberdeen	24"+16" Pipeline in pipe (x1)
1999	Diver	125	Elf/ UK/CSO/Well 14/19-19	30" Multistring conductor (x3)
1999	Diver	20	S.Aramco/M.Dermott/DB27/Ar. Gulf	12" flowline cutting (x2)
1999	Diver	20	S.Aramco/M.Dermott/DB27/Ar. Gulf	6" flowline cutting (x6)
1999	Diver	20	S.Aramco/M.Dermott/DB27/Ar. Gulf	8" flowline cutting (x7)
1999	Diver	20	Kvaerner Cement. / Bharuch-India	48" Piles cutting (x9)
1999	--	--	Total Ind./PT Komaritim Balikpapan	16" pipeline surface cutting (x9)
1999	Diver	10	Total Ind./PT Komaritim Balikpapan	16" c/w c. coat pipeline cutting (x1)
1999	Diver	210	Shell USA - Offshore California	10 3/4" Pipeline cutting with u/w HPU
1999	--	--	Shell USA	10 3/4" Pipeline c. test with u/w HPU
1999	Diver	60	All Seas - Nova Scotia (Canada)	26" ND Pipeline cutting
1999	--	--	BP Foinaven/SCS/Barrow	Flange + studs 10.75" FTA cut test
1999	Diver	40	Walter Oil & Gas USA	30" Multistring Conductor cutting
1999	ROV	100	Phillips/Subsea NORGE	8" ND Coflexip lines (x4)
1999	ROV	250	SSSOL/ETAPS	8 5/8" Guide Post (x3)
1999	Diver	--	OSMCS/USA – Long Beach	Cluster piles cutting (x6)
1999	--	--	OSMCS/USA – All Seas	16" OD Pipe c. test. Active wedge (x1)
1999	Diver	40	WINMAR/USA	48" OD Caisson Cutting (x1)
1999	Diver	40	WINMAR/USA	82" OD Caisson Cutting (x1)
1999	ROV	-	SSSOL/ETAPS - Aberdeen	8 5/8" Guide Post Cutting test (x3)
98/9	Diver	15	SAIPEM ASIA & EMC J.V. – China	14"OD Pipe Cutting (x10)
1998	--	--	SAIPEM ASIA & EMC J.V. – China	14"OD Pipe Cutting test (x1)
1998	--	--	WINMAR/MITCHEL/USA	36" OD Pipe Cutting test
1998	--	--	WINMAR/MITCHEL PTF/USA	81" OD Pipe cutting test (x2)
1998	Diver	2	BARRACUDA SUB/Viareggio	30" Reinforced Concrete piles (x4)
1998	--	--	WOODSIDE/TRITECH/Australia	8 5/8" Guide Post cutting test (x1)
1998	ROV	80	PPCon/SubSea Norge	30" OD Multistring J Tube cutting (x4)
1998	ROV	80	PPCon/SubSea No/Viking Troll	9.5" OD Coflexip line cutting
1998	Diver	15	ETPM/MC DERMOTT Nigeria	24" wt 1/2" Coated Pipeline (x15)
1997	--	--	All Seas Engineering BV/Rott.am	20" wt 1" Pipe Cutting test (PRT)
1997	--	--	Pemex/Oceanographia - USA	36" wt 1 1/4" Pipe cutting test
1997	--	--	Conoco/Coflexip Stena	6" Duplex Pipe cutting test
1997	Diver	40	ELF PETROLAND	30" Multistring conductor (Precision cut)
1997	Diver	40	NAM/EMC/Castoro 6 - Stephaniturm	10" + 2" Concrete Coated pipeline (x6)
1997	ROV	375	OCEANEERING A/S Norway	3" Chain cutting - Back up
1997	Diver	40	ARCO/IEV Indonesia	Tripod 48" conductor + 36"+18"+36" legs
1997	Diver	35	ETPM/MC DERMOTT	16" + 2" coating pipe cutting (x10)
1997	Div/ROV	75	GUPCO/I.N. W./Red Sea	30" Conductor string cutting
1997	--	--	AMOCO/AOC/LOMOND Platform	Pad-ear cutting (x1)





DWCS RECORD (June 2011)



Year	Assisted by	Water Depth (m)	Customer Location	Project Details
1997	--	--	Shell/All Seas/Gulf of Mexico	12" OD Cutting test - 20Lit/min flow
1997	--	--	BAKER O.T./CONOCO/Aberdeen	24" Conductor string cutting test
1997	--	--	BAKER O.T./TS Workshop Genoa	24" pipe (x1) cutting test
1996	--	--	BAKER O.T./CONOCO/N. Sea	13" and 9" casings cutting (x2)
1996	--	--	BAKER O.T./TS Workshop Genoa	24" pipe (x2) + steel plates (x4) c.test
1996	ROV	1.600	Shell/All Seas/Gulf of Mexico	Wet Buck. Cont.cy 6"-16" pipes
1996	--	--	Thomas T. & Sons Ltd/Inverurie	Reinforced concrete block (x3)
1996	ROV	30	Conoco/Seaway H.L./VIKING A Ptf	VIKING - 24" Conductor (x2)
1996	ROV	30	Conoco/Seaway H.L./VIKING Platform	VIKING - 36" Pile cutting (x8)
1996	--	--	Conoco/Seaway H.L./Aberdeen	VIKING - 30" Pile cutting test (x2)
1996	Diver	150	MSR/Coflexip Stena/Emerald	30" Wellhead /30" Conductor string
1996	Diver	150	MSR/Coflexip-Stena/Aberdeen	Emerald Platform Removal/Back-up
1996	Diver	140	MSR/Coflexip-Stena/Aberdeen	Esmond Platform Removal/Back-up
1996	Diver	25	Hamilton/Coflexip-Stena/Orelia	12" pipe (x8) - 30" conductor (x1)
1996	--	--	Thomas T. & Sons Ltd/Inverurie	Reinforced concrete block (x1)
1996	ROV	259	Statoil/Ocean. /SS Tr. Prospect	C /K lines (4), 30" Riser (1), hoses (2)
1996	ROV	--	Noble Drilling/BP Forties 40 Alpha	7 5/8" Casings - Back up
1996	--	--	MSR/Coflexip-Stena/Aberdeen	6" OD flexible pipe cutting test (1)
1996	ROV	191	MOBIL/Oceanering/Equatorial Guinea	10" OD guide post cutting (x4)
1996	--	--	BP/Wood/SCS Aberdeen	16" OD pipe 25° angle cutting test
1996	Div/ROV	75	GUPCO/I.N. W. /Red Sea	20" Conductor string (x2)
1995	--	--	Shell/Cameron/CSO	8,5" OD G. Post cutting test (x1)
1995	ROV	140	GLOBAL/OC./SEDCO FOREX	Drill strings cutting (x2)
1995	ROV	135	TEXACO/SEDCO EXPLORER	6 5/8" OD pipe cutting
1995	ROV	140	Shell/Stolt Comex Seaways	Choke kill lines cutting (x2)
1995	ROV	180	EMC/SSO/British VIKING/Troll	75mm c. frame (x4)+200mm pipe (x2)
1995	Diver	30	CONOCO VIKING/N. Sea	24" Conductor string
1995	ROV	335	SAGA/SONSUB/SNORRE TLP	Drilling strings cutting (x9)
1995	ROV	--	Shell /Oc./Stephaniturn/N. Sea	Corrosion Cup -Back up
1995	ROV	305	STATOIL/Bar Protector/N. Sea	Cup+Seal (J tube)
1995	ROV	80	Shell UK/SSO/Stadive/N. Sea	Brent/SPAR Chain (x2)
1995	ROV	--	Shell UK/SSO/ Stadive/N. Sea	Brent/SPAR Chain cut back-up
1995	--	--	Shell UK/SSO/Aberdeen	Brent/SPAR Chain c. test (x2)
1995	--	--	Gulf Circle/Abu Dhabi	R. Concrete blocks d. test (x3)
1995	--	--	Gulf Circle/Abu Dhabi	30" Conductors demo test (x2)
1995	--	--	STATOIL/CHTS/Aberdeen	Europipe pr. - 16" p. c. test
1995	--	--	All Seas/CHTS/Aberdeen	Troll project - 16" pipe c. test
1995	--	--	CHTS/Aberdeen	16" pipe c. test
1995	ROV	115	UGLANDS/SSO/Armada N.Sea	I beams (2000x600x25) (x2)
1994	--	--	UGLANDS/SSO/Aberdeen	I beam test (2000x600x25)
1994	--	--	HeereMac/Aberdeen	24" pipe, I beam, piston tests
1994	Diver	5	M/V Energy/Genoa Harbour	Propeller blade (bronze)
1994	--	--	Circle Hire T.S./Aberdeen	24" pipe c. test





DWCS RECORD (June 2011)



Year	Assisted	Water	Customer	Project
	by	Depth (m)	Location	Details
1993	Diver	0-70	Texaco/SOL/North Sea	48" caisson (x10)
1993	--	--	Texaco/SOL/Ravenna	48" caisson test
1993	Diver	0-12	Repsol/Tarragona	10 to 50" pipes (x26)
1993	--	--	Rockwater/Aberdeen	20" pipe, engine test
1993	Diver	60	Total/Makasar Straits	30" conductor string (x2)
1993	--	--	Total/Indonesia/Singapore	30" conductor test
1993	Div/ROV	104	Smit/Red Sea	SIDKI 12"+18" risers (x4)
1993	Div/ROV	104	Smit/Red Sea	SIDKI 30"+24" conductors (x10)
1993	Div/ROV	104	Smit/Red Sea	SIDKI Platform Legs
1992	Diver	22	Smit/North Sea	M/V Stora
1992	--	--	Smit/Ravenna/Rotterdam	M/V Stora tests
1992	ROV	600	NOS/Jonian Sea	20" pipe SAS
1992	--	--	NOS/Ravenna	20" pipe SAS test
1992	30	30	Seaway/Off. Nigeria	Albaz J/U legs
1992	Diver	15	Furlanis/Trieste	48" OD Sealines (x2)
1992	Diver	15	Furlanis/Trieste	60" OD Sealines (x2)
1992	Diver	25	Agip/Adriatic Sea	1800mm OD Monopile Ptf. (x3)
1991	--	--	Agip/Ravenna	1200mm OD pipe c. test
1991	Diver	45	Agip/Adriatic Sea	12 (x2), 10" OD risers (x2)
1991	Diver	35	Agip/Adriatic Sea	4 legs jacket (x3)
1991	Diver	45	Agip/Adriatic Sea	8 legs jacket (x1)
1990	--	--	TS/Ravenna	12, 16" pipes test (x6)

