

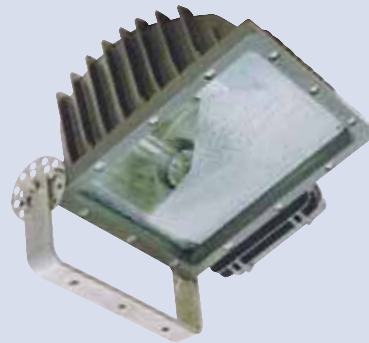

Recommended maximum aiming angle 20° from horizontal plane



Optional PTFE Coating

The Evolution II is a photometrically advanced floodlight that combines Ex de protection with optimised utilisation of light through its asymmetric design. The Evolution concept has no exposed flamepaths making the luminaire effectively maintenance free. Access to the lamp and terminal chamber is achieved by the unscrewing of a single captive bolt

Standard Specification		Features
Type of Protection	Ex d e (Flameproof, Increased Safety) Dust protected enclosure	Installation in gas groups IIA and IIB
ATEX Classification	Group II Category 2 GD	Easy and quick access for maintenance
Area Classification	Zone 1 and Zone 21 areas to EN 60079-10-1 and EN 60079-10-2 with installation to EN 60079-14 Gas Groups IIA and IIB	Simple, rapid lamp replacement and flamepath inspection
Certificate	EC Type Examination Certificate Baseefa04ATEX0155	Reduced maintenance due to no exposed flamepath
Coding	Ⓔ II 2 GD Ex d e IIB	Exceptional photometric efficiency with reduced glare
Enclosure	Refer to table for T rating and Ambient Aluminium alloy LM6 to BS 1490 (AC44100) All fastenings A4 stainless steel Toughened glass window	Timed ignitor supplied as standard
Reflector	Asymmetric beam, high purity anodised aluminium	
Entry	2 x M20 cable entries	
Termination	3 core 6mm ² max. conductor with looping	
Installation	Stirrup mounting bracket with aiming quadrant	
Windage	0.112m ²	
Control Gear	Internal copper/iron with PFC correction capacitor and timed ignitor	
Relamping	Access via hinged end cover on release of single screw	
Burning Position	Universal for HID, +/-45° on horizontal plain for Tungsten-Halogen lamps	
Ingress Protection	IP66/67 to EN 60529	
Electrical Supply	220, 230, 240, 254V 50Hz HPS & Metal Halide 24V - 254V Linear Tungsten-Halogen, 110V - 254V Single ended Tungsten-Halogen	
		International Approvals
		ATEX, GB (China) and GOST
		IECEx Compliant

Std. Cat No.	Wattage	Lamp	Lampholder	T Class (Gas)	T °C (Dust)	Ambient °C	Weight
EV2D/150/MS	150W	HPS and Metal Halide	E40	T4	130	-20 to +40	28.0kg
				T3	175	-20 to +55	
EV2D/250/MS	250W	HPS and Metal Halide	E40	T4	130	-20 to +40	28.5kg
				T3	175	-20 to +55	
EV2D/400/MS	400W	HPS and Metal Halide	E40	T3	175	-20 to +55	28.5kg
EV2D/600/HS*	600W	HPS	E40	T3	195	-20 to +35	25.0kg
EV2D/500/TH	500W	Single Ended T/Halogen	E40	T3	195	-20 to +40	25.0kg
EV2D/500/TL	500W	Linear T/Halogen	R7s	T3	195	-20 to +55	25.0kg

*Ignitor only fitted. Remote gear box required (see Universal Box).

Note: Please specify voltage at time of enquiry/order

Options – Suffix to Catalogue No.

/120	110V - 130V (Weight increase of +10kg) HPS and Metal Halide lamps only	/P	PTFE coating
/60	60Hz	/PE	Pendant mounted
/208-60	208V 60Hz	/N	Narrow beam option
/M25	M25 cable entries	/IEC	Supplied with IECEx certification label

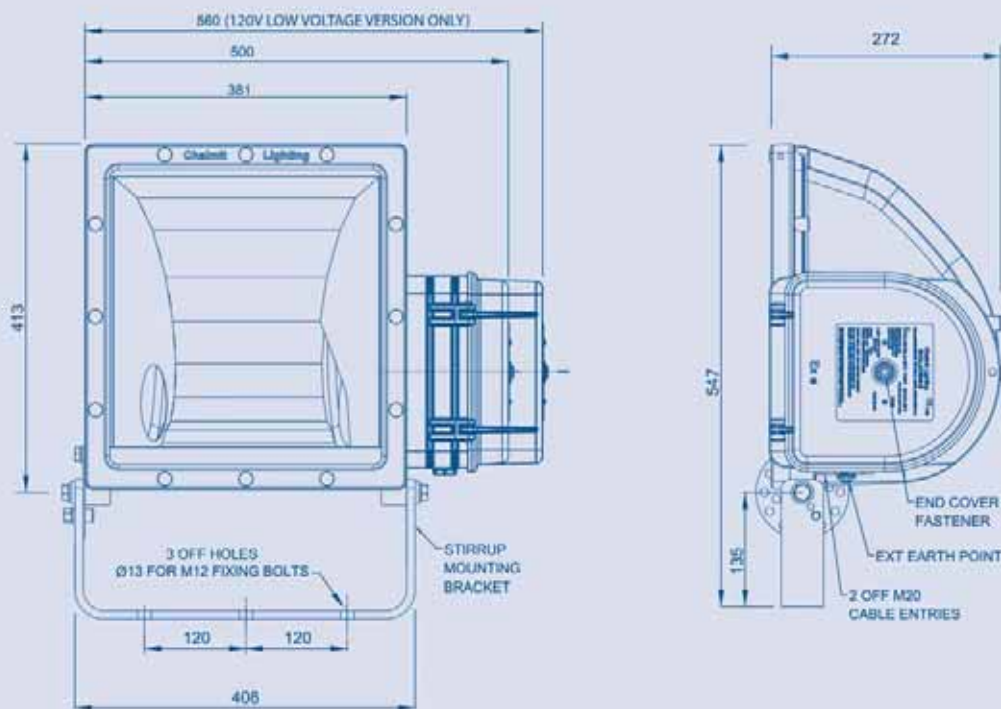

NOTE: 120V version utilises deeper end cover (as shown above)

Accessories Should be ordered separately

Catalogue Order Code

Product design and specifications are subject to change without notice, please check the Chalmit website for latest specifications.

EVOLUTION RANGE

3

Evolution II & Evolution Guards and Shields

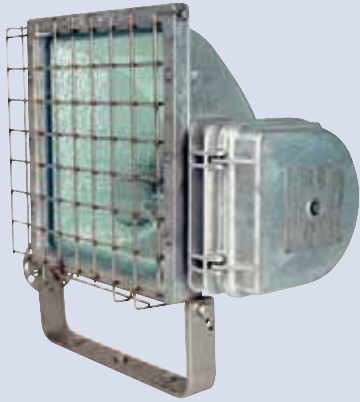

Evolution II	
Wire Guard	SEV04-0020
Evolution	
Anti-Glare Shield	SEV04-0002
Wire Guard	SEV04-0003
Combined Anti-Glare Shield and Wire Guard	SEV04-0008

Evolution Anti-Glare Shield

Combined Anti-Glare Shield and Wire Guard

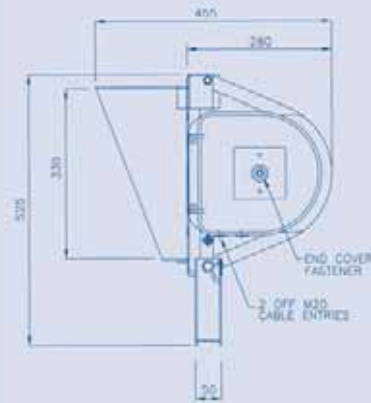

Swing Jib Damper & Bracket Assembly

Evolution only

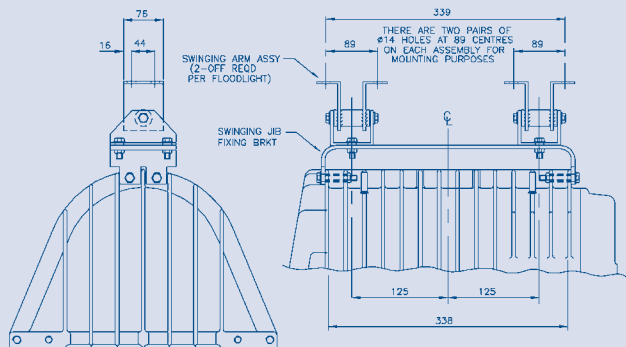
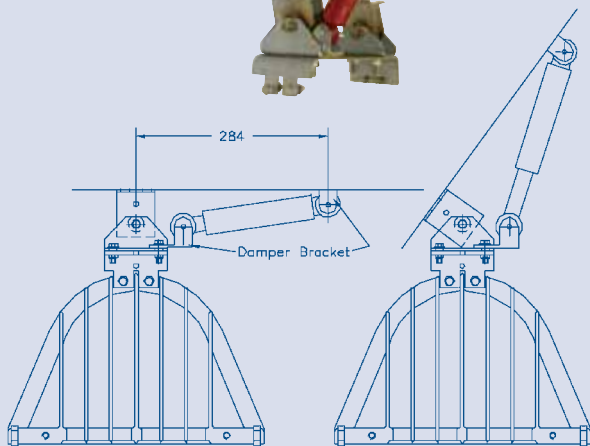
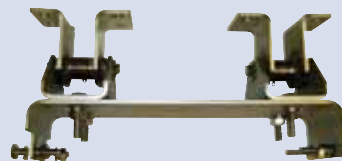

Damper assembly - SEV01-0015

Bracket assembly - SEV04-0009

Pole Mounting Bracket Assembly

Cat No. SEVO4-0001

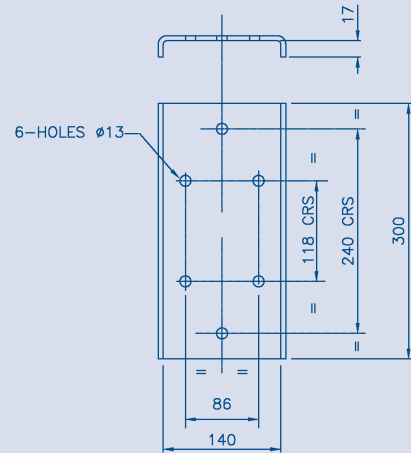
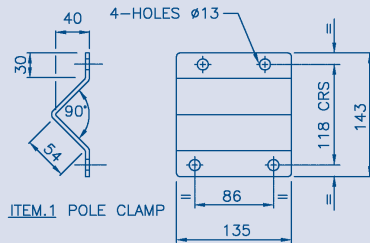

284 Retrofit Bracket

Cat No. SEVO1-0001

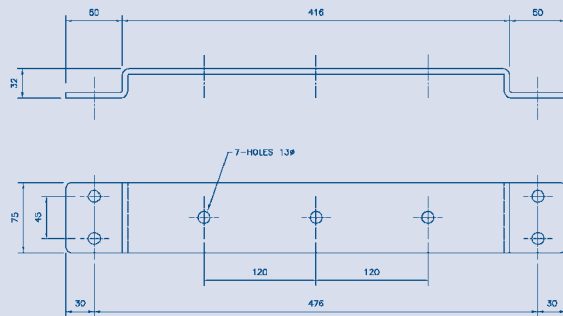

Evolution Junior Mounting Accessories

Cat No. SEVJR-0001/SEVJR-0002



Floor assembly SEVJR-0001



Tripod assembly SEVJR-0002