



The Centuria with external reflector



The Centuria with angle reflector

The Centuria embodies the philosophy of low maintenance design. Easy access is gained to the enclosure via a single bolt ensuring quick maintenance to the lamp housing and control gear reduces installation time and overall lifetime cost. Centuria also features no exposed flamepath removing the need for additional inspection and maintenance.

Designed from the highest quality marine grade materials and combined with a range of mounting options and reflectors, Centuria provides a flexible lighting solution for almost any area lighting application.

Standard Specification		Features
Type of Protection	Ex d e m (Flameproof, Increased safety, Encapsulated), Ex tD (Dust)	Installation to gas groups IIA, IIB & IIC
ATEX Classification	Group II Category 2 GD	Ex e cable entries and looping as standard
Area Classification	Zone 1 and Zone 21 areas to EN 60079-10-1 and EN 60079-10-2 with installation to EN 60079-14 Gas Groups IIA, IIB and IIC	High ingress protection
Certificate	EC Type Examination Certificate - pending IECEX - pending	External reflector (optional)
Coding	Ⓔ II 2 G Ex d e mb IIC T* Gb Ⓔ II 2 D Ex tb IIIC T*** °C Db IP6X (Refer to table for T rating and Ambient)	Low temperature to -55°C
Enclosure	Aluminium alloy LM6 to BS 1490 (AC44100) All fastenings A4 stainless steel Toughened glass dome globe	Timed ignitor as standard
Entry	2 x M20 cable entries	
Termination	3 core 6mm ² max. conductor with looping	
Installation	Ceiling mounting	
Windage	0.13m ² (up to 150W Glass) 0.17m ² (>150W Glass) 0.21m ² (Enclosed Reflector)	
Control Gear	Internal copper/iron with PFC correction capacitor	
Lampholder	E40	
Relamping	Access via hinged cover on release of single screw	
Ingress Protection	IP66/67 to EN 60529	
Electrical Supply	220V, 230V, 240V, 254V 50Hz 150W, 250W & 400W (HPS/Metal Halide)	

Std. Cat No.	Wattage	Lamp	T Class (Gas)	T° (Dust)	Ambient °C	Weight
CEND/150/MS	150W	HPS or Metal Halide	T4	130	40	15.0kg
			T3	145	55	
CEND/250/MS	250W	HPS or Metal Halide	T3	185	55	18.0kg
CEND/400/MS	400W	HPS or Metal Halide	T3	195	45	19.5kg
CEND/500/TH	500W	Single Ended T/Halogen	T3	190	55	14.5kg

Options – Suffix to Catalogue No.

/60	60Hz	/ST	Stanchion mounted version
/M25	M25 cable entries	/PE	Pendant mounted version
/WM	Wall mounted version	/S	Stirrup mounted version

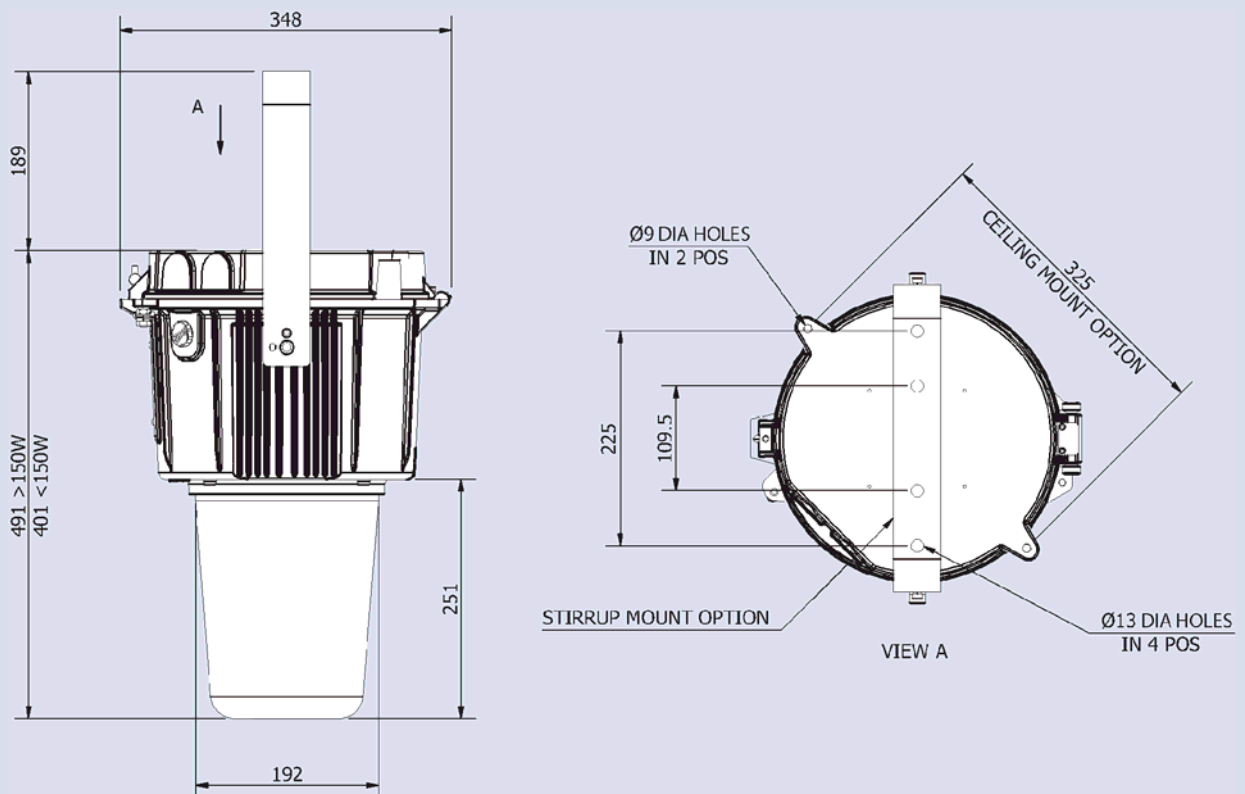

Accessories should be ordered separately

Catalogue Order Code

Wire guard for low wattage glass globe (up to 150W)	E0850-0042
Wire guard for high wattage glass globe (250W/400W)	E0850-0044
Dome reflector	HEC20-0001
30° angled reflector	HEC20-0002

Product design and specifications are subject to change without notice, please check the Chalmit website for latest specifications.

