

BUCHAN TECHNICAL SERVICES

Buchan Technical Services Ltd, a member of James Fisher and Sons plc, was established in 1997 to provide equipment rental and Recruitment services to the oil and gas industry.

We have hands on experience of most oil and gas related tasks and this knowledge allows us to best meet your recruitment and equipment rental requirements.

Equipment Rental

Triplex fluid pumps
Pipeline flooding pumps
Powered umbilical reels
High pressure jetting
Hydraulic power packs
Hose and umbilicals

Recruitment

Pipeline pigging and testing
Nitrogen / Helium leak detection
Fluid pumping
CRI / Filtration / Skip & ship
Abandonment
Equipment operators

Many of our up to date vacancies and equipment specification sheets can be found on our web site www.buchantechnical.co.uk

We are ISO 9001, ISO 14001 & OHSAS 18001 Registered, 1st Point Assessment Registered and members of the Recruitment and Employment Confederation.

Buchan Technical Services Limited,
Unit 7, Fisher Offshore Base, North Meadows,
Oldmeldrum, Aberdeenshire, Scotland. AB51 0GQ
Tel: +44 (0) 1651 871450 Fax: +44 (0) 1651 871459
info@buchantechnical.co.uk www.buchantechnical.co.uk
Member of James Fisher and Sons plc

Registered in Scotland No. 177590- Registered Office North Meadows, Oldmeldrum, Aberdeenshire. AB51 0GQ



1" UMBILICAL REEL



POWER DRIVE SPECIFICATION

Air Motor Type	: Multivane
Air consumption	: 150 cfm. @ 7 Bar
R.P.M.	: 2500
H.P.	: 4.8
Braking	: Via. worm box.
Output shaft to drive sprocket ratio	: 4 - 1
Chain	: 25mm Pitch
DRUM	
Speed	: 6.5 R.P.M.
Line Pull	: 1.3 Tonnes
Hose Storage Capacity	: Varies according to hose weight + dia
Inner Drum Diameter	: 860 mm
Outer Drum Diameter	: 1447 mm
Length of Drum	: 990 mm

DIMENSIONS

Length	: 2000 mm
Width	: 1450 mm
Height	: 2150 mm
Tare Weight	: 1000 Kg
Gross Weight	: 3000 Kg

All specifications correct at time of printing, but may be altered subsequently by the company

Buchan Technical Services Limited,
Unit 7, Fisher Offshore Base, North Meadows,
Oldmeldrum, Aberdeenshire, Scotland. AB51 0GQ
Tel: +44 (0) 1651 871450 Fax: +44 (0) 1651 871459
info@buchantechnical.co.uk www.buchantechnical.co.uk
Member of James Fisher and Sons plc

Registered in Scotland No. 177590- Registered Office North Meadows, Oldmeldrum, Aberdeenshire. AB51 0GQ



2" UMBILICAL REEL



SPECIFICATION

Hydraulic Drive Motor Type	: Rotary Piston
Hydraulic consumption	: 17 gpm @ 3000 psi
Braking	: Caliper and drum (Dual system)
Chain Drive	: Via 1 ½" pitch chain

DRUM

Speed	: 4 R.P.M.
Line Pull	: 2 Tonnes
Hose Storage Capacity	: 400m of 2" 80 BAR hose c/w BSP Connections
Inner Drum Diameter	: 900 mm
Outer Drum Diameter	: 1700 mm
Length of Drum	: 1520 mm

DIMENSIONS

Length	: 2975 mm
Width	: 2010 mm
Height	: 2450 mm

WEIGHT

Tare Weight	: 3000 Kg
Gross Weight	: 10,000 Kg

All specifications correct at time of printing, but may be altered subsequently by the company

Buchan Technical Services Limited,
Unit 7, Fisher Offshore Base, North Meadows,
Oldmeldrum, Aberdeenshire, Scotland. AB51 0GQ
Tel: +44 (0) 1651 871450 Fax: +44 (0) 1651 871459
info@buchantechnical.co.uk www.buchantechnical.co.uk
Member of James Fisher and Sons plc

Registered in Scotland No. 177590- Registered Office North Meadows, Oldmeldrum, Aberdeenshire. AB51 0GQ



4" UMBILICAL REEL



POWER DRIVE SPECIFICATION

Air Motor Type	: Rotary piston
Air consumption	: 400 cfm. @ 8.0 Bar
R.P.M.	: 1600
H.P.	: 14 Kw Peak
Braking	: Via.worm box.
Output shaft to drive sprocket ratio	: 4.3 : 1
Chain	: 1 ½ " Pitch heavy duty simplex

DRUM

Speed	: 2.25 R.P.M.
Line Pull	: 5 tonne Max.
Hose Storage Capacity	: [700m x 2"][450m x 4"][250m x 6"]
Inner Drum Diameter	: 1600 mm
Outer Drum Diameter	: 2745 mm
Length of Drum	: 2285 mm

DIMENSIONS

Length	: 2845 mm
Width	: 3280 mm
Height	: 3047 mm

Tare Weight	: 6400 Kg
Gross Weight	: 13000 Kg

Certification : Tested to DNV CN2.7-1

All specifications correct at time of printing, but may be altered subsequently by the company

Buchan Technical Services Limited,
Unit 7, Fisher Offshore Base, North Meadows,
Oldmeldrum, Aberdeenshire, Scotland. AB51 0GQ
Tel: +44 (0) 1651 871450 Fax: +44 (0) 1651 871459
info@buchantechnical.co.uk www.buchantechnical.co.uk
Member of James Fisher and Sons plc

Registered in Scotland No. 177590- Registered Office North Meadows, Oldmeldrum, Aberdeenshire. AB51 0GQ



6" UMBILICAL REEL



POWER DRIVE SPECIFICATION

Air Motor Type	: Twin Direct Drive
Air consumption	: 600 cfm
H.P.	: 20
Braking	: Manual operated brake band system

DRUM

Speed	: 4 R.P.M.
Line Pull	: 3.5 tonne Max.

Inner Drum Diameter	: 2000 mm
Outer Drum Diameter	: 3200 mm
Length of Drum	: 1800 mm

DIMENSIONS

Length	: 3500 mm
Width	: 3000 mm
Height	: 3800 mm

Tare Weight	: 6000 Kg
Gross Weight	: 16000 Kg

Certification	: BS 7072
---------------	-----------

All specifications correct at time of printing, but may be altered subsequently by the company

Buchan Technical Services Limited,
Unit 7, Fisher Offshore Base, North Meadows,
Oldmeldrum, Aberdeenshire, Scotland. AB51 0GQ
Tel: +44 (0) 1651 871450 Fax: +44 (0) 1651 871459
info@buchantechnical.co.uk www.buchantechnical.co.uk
Member of James Fisher and Sons plc

Registered in Scotland No. 177590- Registered Office North Meadows, Oldmeldrum, Aberdeenshire. AB51 0GQ



HOSE REEL SPECS

Air powered hose reels for hose storage, deployment and recovery, for pipeline commissioning and testing, subsea wellhead control and intervention, diving and dredging operations, subsea equipment operations, retrojetting, grouting, corrosion inspection and cleaning, air lifts etc.

Model	Horsepower	Line Pull	Storage Capacity
Hand Reel	-	20kg	200m of ¼" hose
1"	4	0-8 to 1-4 tonnes	900m of 1" hose
2"	11	3 to 5 tonnes	450m of 2" 1502
4"	14	3 to 5 tonnes	2000m of 1" hose 750m of 2" 1502 500m of 4" Dunbar 180m of 6" Dunbar
6"	20	3 tonnes	200m of 6" Dunbar

Selection of details for information only.

Contact vendor for storage and retrieval capacities.

Buchan Technical Services Limited,
 Unit 7, Fisher Offshore Base, North Meadows,
 Oldmeldrum, Aberdeenshire, Scotland. AB51 0GQ
 Tel: +44 (0) 1651 871450 Fax: +44 (0) 1651 871459
info@buchantechnical.co.uk www.buchantechnical.co.uk
 Member of James Fisher and Sons plc
 Registered in Scotland No. 177590- Registered Office North Meadows, Oldmeldrum, Aberdeenshire. AB51 0GQ



SUBSEA UMBILICAL HOSE

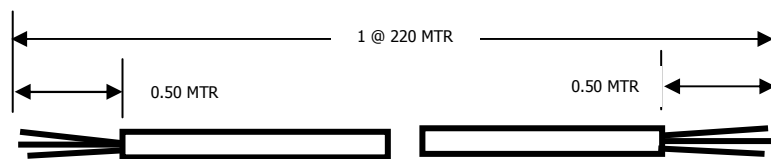
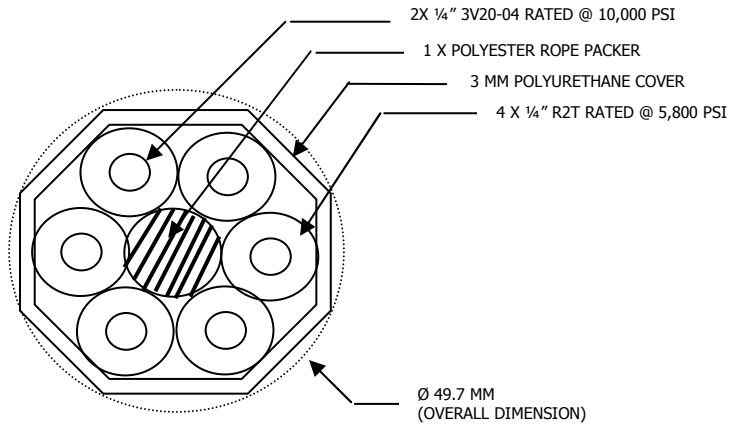

Min. Bend Radius	:	300 mm (Static)
Min. Bend Radius	:	450 mm (Dynamic)
Colour	:	Orange
Legend	:	Buchan Technical Services Ltd

220 meters long
 2 off 1/4" lines rated @ 10,000 psi working pressure
 4 off 1/4" lines rated @ 5,800 psi working pressure

All specifications correct at time of printing, but may be altered subsequently by the company

Buchan Technical Services Limited,
 Unit 7, Fisher Offshore Base, North Meadows,
 Oldmeldrum, Aberdeenshire, Scotland. AB51 0GQ
 Tel: +44 (0) 1651 871450 Fax: +44 (0) 1651 871459
info@buchantechnical.co.uk www.buchantechnical.co.uk
 Member of James Fisher and Sons plc

Registered in Scotland No. 177590- Registered Office North Meadows, Oldmeldrum, Aberdeenshire. AB51 0GQ



6" DO40H FUEL AND OIL SUCTION AND DELIVERY 40 BAR (600 PSI)



- Manufacturer: Phoenix Beattie
- Reinforcement: High Tensile Textile Cords with Embedded Steel Helix Wire and Anti-static Wire
- Cover: Black CR/BR Blend, Abrasion, Ozone and Hydrocarbon Resistant
- Temperature Range: -25°C to +80°C

Typical Application: Fuel Oil Suction and Delivery with up to 50% Aromatic Content Suitable for Seawater, Mud and General Offshore Applications. Long Lasting in Bunkering Applications.

Part No.	Inside		O.D.	Working		Minimum		Min Bend	Weight
	Dia			Pressure		Burst Pressure			
	mm	inch	mm	Bar	PSI	Bar	PSI	mm	Kg/M
D040H-096	152	6	195	40	600	155	2250	912	16

Supplied in 10m lengths c/w 6" Fig 100 M/F connections.

A total length of 160m available with/without Powered Umbilical Reel.

Buchan Technical Services Limited,
 Unit 7, Fisher Offshore Base, North Meadows,
 Oldmeldrum, Aberdeenshire, Scotland. AB51 0GQ
 Tel: +44 (0) 1651 871450 Fax: +44 (0) 1651 871459
info@buchantechnical.co.uk www.buchantechnical.co.uk
 Member of James Fisher and Sons plc
 Registered in Scotland No. 177590- Registered Office North Meadows, Oldmeldrum, Aberdeenshire. AB51 0GQ



Spec	Engine	HP	Pump	Duty	Medium
CENTRIFUGAL PUMPS					
Rigsafe WP24	Caterpillar 3412	670	RKB 200/37 5 stage	1800igpm @ 16 bar 840igpm @ 40 bar	Water
Rigsafe WP23	Caterpillar 3412	670	Hydrostream BSO8C single stage	3000igpm @ 15 bar	Water
Zone II WP06	Detroit 8V71	300	Weir 5 stg centrifugal	28bar / 1300 gpm	Sea Water
Zone II WP36	Detroit 8V71	300	Sterling 5 stg centrifugal	25bar / 1000 gpm	Sea Water
Rigsafe WP11	Detroit 8V71	300	SPP 2stg centrifugal	18bar / 1300 gpm	Sea Water
Rigsafe WP22	Scania DS11	200	2stg centrifugal	18bar/1000gpm	Sea Water
Zone II WP12	Iveco 7675	100	4x3 centrifugal	800gpm (9@13,500psi)	Sea Water
Zone II WP17	Ford 2725	100	Series 250 4x3x13	9 bar / 700 gpm	Chemicals / mud
Zone II WP40	Ford 2725	100	4" x 3" Single Stage	8 bar / 800 gpm	Sea Water
Hydraulic WP41+42	Hydraulic Driven	100	4" x 3" x 11" Single Stage	8 bar / 800 gpm	Sea Water
Zone I WP20+21	3 phase electric	45kw 52kw	Series 250 4x3x8	700gpm/7bar	Chemicals / mud
Safe Area	3 phase electric submersible	415V 50Hz 18.5kw	KSB non flameproof 4" discharge	800gpm @ 1.5bar 222gpm @ 2.5 bar	Slurry compatible
Zone I AS01	Air driven	2	Air driven submersible	280gpm or 1.4 bar	Sumps/ trash
Rigsafe HV03	Iveco	160	5 stg Sterling	3.5M ³ @10BAR 0.7M ³ @25BAR	Sea Water Fresh Water
Rigsafe WP04	Volvo TD121G	250	BM06J SPP 2 Stg pump	1000gpm @ 15 BAR	Sea Water Fresh Water
Rigsafe WP11	Detroit 8VA 71.N	240	Ingersol Dresser S/S	291M/hr 77.6 head	Water/SeaWater
			SPP Twin stg split case	1300gpm@1760rpm	Water/SeaWater
			5 stg Sterling	3.5M ³ @10BAR	Water/SeaWater
Zone II WP14	Ford 2725	100	4"X3" Single stage	10 BAR @ 2200rpm	Water/SeaWater
Electric WP19	Jet 251		Single phase 240v 2.2Kw	Max head 6 BAR	Safe Area use only
Zone II WP27	Detroit 8V71	320	5 Stg Sterling	3.5M ³ @10BAR 0.7M ³ @25BAR	Water/SeaWater Chemicals
Rigsafe WP31	Perkins Dorman V12	910	RKB 200 37 5 stg Hidrotecar ZM11	227 – 500M ³ hr 1200M ³ hr	Water/SeaWater

Buchan Technical Services Limited,
 Unit 7, Fisher Offshore Base, North Meadows,
 Oldmeldrum, Aberdeenshire, Scotland. AB51 0GQ
 Tel: +44 (0) 1651 871450 Fax: +44 (0) 1651 871459
info@buchantechnical.co.uk www.buchantechnical.co.uk
 Member of James Fisher and Sons plc
 Registered in Scotland No. 177590- Registered Office North Meadows, Oldmeldrum, Aberdeenshire. AB51 0GQ



Spec	Engine	HP	Pump	Duty	Medium
POSITIVE DISPLACEMENT PUMPS					
Zone II WP15+32	Detroit 12V71	485	Halliburton HT400 4½" Fluid End	10k psi : 350gpm	Water / Mud / Cement/ Chemicals
Zone II WP28	Detroit 8V92	340	Halliburton HT400 4½" Fluid End	10k psi : 350gpm	Water / Mud / Cement/ Chemicals
Zone II WP32+15	Detroit 12V71	485	Halliburton HT400 6" Fluid End	2.79M ³ @430BAR	Water / Mud / Cement / Chemicals
Rigsafe WP33	Detroit 8V92T	400	Halliburton HT400 4½" Fluid End 6" Fluid End	10k psi : 350gpm 2.79M ³ @430BAR	Water / Mud / Cement/ Chemicals
Rigsafe WP27	Detroit 6V71	240	Halliburton HT400 3 3/8" Fluid End	10,000psi	Water / Mud / Cement /Chemicals
Rigsafe WP02	Rolls Royce 6 cyl	220	Hughes Jetin 2000	23 gpm / 8300 psi	Seawater
Zone II WP16	Iveco 7675si	158	Neolith NP160	15gpm/12000psi 48gpm/3850psi	Seawater
Zone II WP29/30	Iveco 7675si	158	Neolith NP80	9gpm/13500psi	Water
Zone II WP12	Iveco 7675	150	Neolith NP80 FMC L1122D Hughes Jetin 2000	18gpm@6750psi 0-75gpm@1000psi 23 gpm / 8300 psi	Seawater / Inhibitors
Zone II WP14+16	Ford 2725	100	Neolith NP80	18gpm / 6750psi 9gpm / 13500 psi	Seawater / Inhibitors
Zone II HPP26	Detroit 4-71	150	Aqua Hydraulics / Jetch	24 litres/minute @ 36,000psi	Fresh Water
Zone I	Air Driven	0.5	Haskel	0.6Lpm/1000bar	Water
Zone II WP17	Ford 2725	100	Neolith 160 4"x3" single stage FMC L1122D	0-60gpm@2050psi 800gpm@10bar 0-75gpm@1000psi	Water / Mud / Cement/ Chemicals
Rigsafe WP22	Scania DS11	200	Hughes Jetin 2000	23gpm@8300psi	Water / Mud / Cement/ Chemicals
Rigsafe WP36	Detroit Diesel 6V71	220	Hughes Jetin 2000	37.5gpm@5000psi	Water / Mud / Cement/ Chemicals
WP43					Under construction

Buchan Technical Services Limited,
Unit 7, Fisher Offshore Base, North Meadows,
Oldmeldrum, Aberdeenshire, Scotland. AB51 0GQ
Tel: +44 (0) 1651 871450 Fax: +44 (0) 1651 871459
info@buchantechnical.co.uk www.buchantechnical.co.uk
Member of James Fisher and Sons plc
Registered in Scotland No. 177590- Registered Office North Meadows, Oldmeldrum, Aberdeenshire. AB51 0GQ



ZONE II 12V-71 HT400 PUMP UNIT



Buchan Technical Services Limited,
 Unit 7, Fisher Offshore Base, North Meadows,
 Oldmeldrum, Aberdeenshire, Scotland. AB51 0GQ
 Tel: +44 (0) 1651 871450 Fax: +44 (0) 1651 871459
info@buchantechnical.co.uk www.buchantechnical.co.uk
 Member of James Fisher and Sons plc
 Registered in Scotland No. 177590- Registered Office North Meadows, Oldmeldrum, Aberdeenshire. AB51 0GQ



ZONE II 12V-71 HT400 PUMP UNIT



Equipment Identity No.	-	W.P.15
ENGINE TYPE	-	DETROIT DIESEL 12V 71
Fuel Type	-	Diesel
Hydraulic Horsepower	-	345 (N60 injectors)
Transmission	-	Allison 5 speed CLT 754 HD
Ratios	-	5.18, 3.19, 2.02, 1.38, 1.00
Fuel capacity	-	70 gallons
TRIPLEX PUMP	-	Halliburton HT400 4½” plungers
Gear ratio	-	8.4:1
Max Pressure	-	10,000 psi
Max Rate	-	10 BPM
Discharge Connections	-	2 x 3” 1502 and 2 x 2” 1502
Suction Connection	-	5” Fig 50 / 4” 150 / 4” 200
CONTROL PANEL	-	Externally mounted control panel with all essential gauges, controls and shut down systems. Rexroth 5 speed air operated transmission control with quick neutral button
CERTIFICATION	-	OCMA MEC I ZONE 2
LIFTING CERT'S	-	Housed in a 20' shipping container certified to DNV 2.7-1.
DIMENSIONS		
Height	2860 mm	Length 6100 mm
Width	2430 mm	Weight 13,500 kg (Gross)

All specifications correct at time of printing, but may be altered subsequently by the company.

Buchan Technical Services Limited,
 Unit 7, Fisher Offshore Base, North Meadows,
 Oldmeldrum, Aberdeenshire, Scotland. AB51 0GQ
 Tel: +44 (0) 1651 871450 Fax: +44 (0) 1651 871459
info@buchantechnical.co.uk www.buchantechnical.co.uk
 Member of James Fisher and Sons plc
 Registered in Scotland No. 177590- Registered Office North Meadows, Oldmeldrum, Aberdeenshire. AB51 0GQ



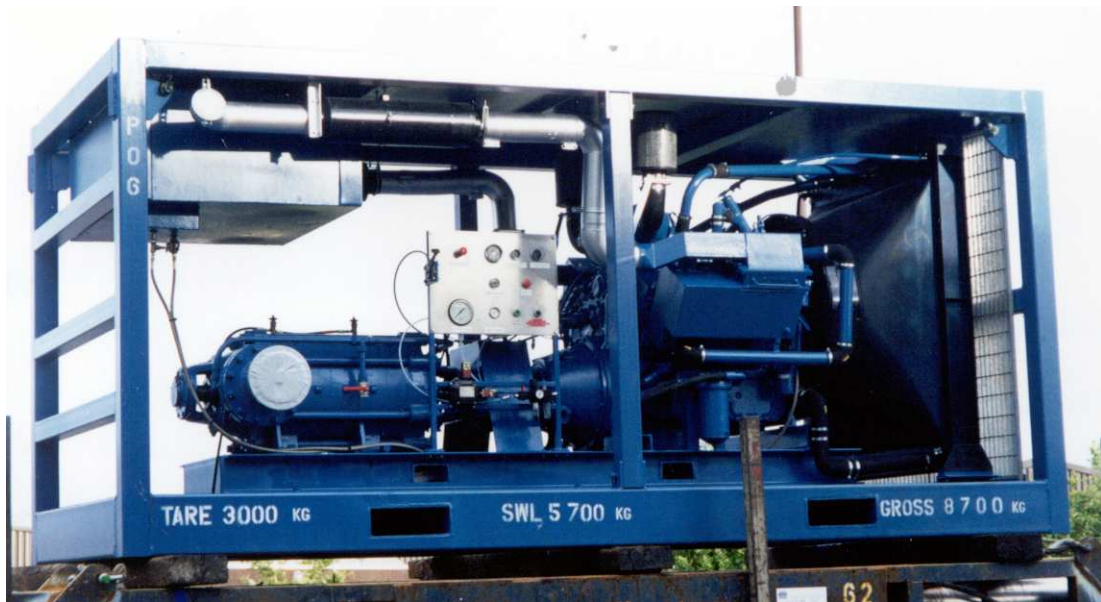

ZONE II DIESEL DRIVEN CENTRIFUGAL PUMP SET

ENGINE TYPE

Fuel Type	DETROIT 8VA71
Maximum R.P.M.	Diesel
Starting System	1800
H.P.	Air Motor
Fuel Tank Capacity	271 @ 1800 R.P.M.
	140 IMP Gal.

PUMP TYPE

Max Flow	WEIR FRD-5 Stage Spiroglide
Max Pressure	1351 igpm
Clutch type	29 BAR
Discharge flange	Anderton Overcentre Twin Plate
Suction flange	6" / 4" 300lb
	8" 150lb

DIMENSIONS

Height	2135 mm	Length	4500 mm
Width	2050 mm	Weight	8.7 Tons

CERTIFICATION

OCMA MEC - 1 ZONE II	CN2.7-1
----------------------	---------

All specifications correct at time of printing, but may be altered subsequently by the company

Buchan Technical Services Limited,
 Unit 7, Fisher Offshore Base, North Meadows,
 Oldmeldrum, Aberdeenshire, Scotland. AB51 0GQ
 Tel: +44 (0) 1651 871450 Fax: +44 (0) 1651 871459
info@buchantechnical.co.uk www.buchantechnical.co.uk
 Member of James Fisher and Sons plc

Registered in Scotland No. 177590- Registered Office North Meadows, Oldmeldrum, Aberdeenshire. AB51 0GQ



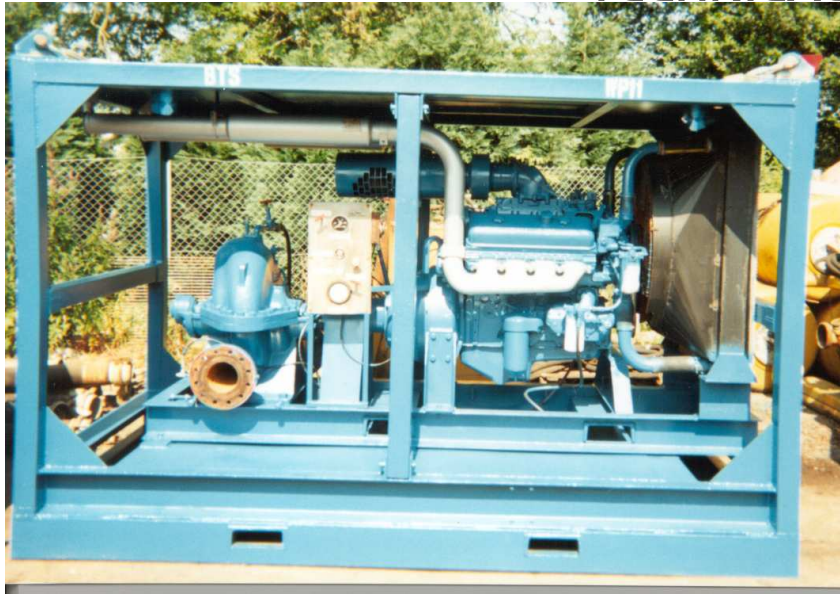

RIGSAFE DIESEL DRIVEN CENTRIFUGAL PUMP SET

ENGINE TYPE	:	DETROIT 8VA 71.N
Fuel Type	:	Diesel
Maximum R.P.M.	:	2300
Starting System	:	Air Motor
Clutch Type	:	Anderton Overcentre Twin Plate
H.P.	:	240 @ 1800 R.P.M.
Full Tank Capacity	:	140 Imp. Gal
PUMP TYPE	:	S.P.P. Twin Stage Split Case
Max Flow	:	1300 IGPM (350 M ³ hr) @ 1760 RPM
Max Pressure	:	18 BAR
Discharge Gate Valve	:	4" A.S.A. 300lb
DIMENSIONS		
Height	:	7' 7"
Length	:	11' 6"
Width	:	5' 8"
Weight	:	6 Tons
Identification No.	:	W.P.11

All specifications correct at time of printing, but may be altered subsequently by the company

Buchan Technical Services Limited,
 Unit 7, Fisher Offshore Base, North Meadows,
 Oldmeldrum, Aberdeenshire, Scotland. AB51 0GQ
 Tel: +44 (0) 1651 871450 Fax: +44 (0) 1651 871459
info@buchantechnical.co.uk www.buchantechnical.co.uk

Member of James Fisher and Sons plc

Registered in Scotland No. 177590- Registered Office North Meadows, Oldmeldrum, Aberdeenshire. AB51 0GQ



RIGSAFE DIESEL DRIVEN 5 STG CENTRIFUGAL PUMP SET



<u>ENGINE TYPE</u>	:	CATERPILLAR 3412 Dual Turbo
Fuel Type	:	Diesel
Maximum R.P.M.	:	2000
Starting System	:	Air Motor
Clutch Type	:	JBJ 18" twin plate
H.P.	:	670 HP max, duty 603 HP
Radiator	:	Rated for 600 HP at 40°C ambient
Fuel Tank Capacity	:	280 Imp. gals
Fuel Consumption	:	30 gals per hour under full load
Controls	:	Externally mounted control panel c/w all controls and gauges
Shut down systems	:	Oil operated - stop, emergency stop, overspeed, high water temp, low oil pressure
<u>PUMP TYPE</u>	:	RKB 200/37 5 stage
Pump duty	:	840 igpm @ 40 bar @ 1800 rpm (227 m ³ hr)
	:	1800 igpm @ 16 bar @ 1500 rpm (500 m ³ hr)
		(See graph for other flow and pressure requirements)
Closed in discharge pressure	:	42 Bar at 1800 rpm
Standard Connections	:	10" 150 suction, 6" 300 discharge
<u>DIMENSIONS</u>		
Height	:	2930mm
Length	:	6096mm
Width	:	2530mm
Gross Weight	:	14,500 kg (BS EN 12079 : 1999, DNV 2.7-1)
Identification No.	:	W.P.23

ALL SPECIFICATIONS CORRECT AT TIME OF PRINTING, BUT MAY BE ALTERED SUBSEQUENTLY BY THE COMPANY

Buchan Technical Services Limited,
 Unit 7, Fisher Offshore Base, North Meadows,
 Oldmeldrum, Aberdeenshire, Scotland. AB51 0GQ
 Tel: +44 (0) 1651 871450 Fax: +44 (0) 1651 871459
info@buchantechnical.co.uk www.buchantechnical.co.uk
 Member of James Fisher and Sons plc

Registered in Scotland No. 177590- Registered Office North Meadows, Oldmeldrum, Aberdeenshire. AB51 0GQ



ZONE II DIESEL DRIVEN CENTRIFUGAL PUMP



Equipment Identity No.	:	W.P.40
ENGINE TYPE	:	Zone 2 Ford 2725
Fuel Type	:	Diesel
Maximum R.P.M.	:	2000
Starting System	:	Air Motor
H.P.	:	100 H.P.
Transmission	:	Direct drive
Fuel Tank Capacity	:	40 IMP GAL
PUMP TYPE	:	4" x 3" single stage
Max pressure	:	8.5 bar @ 2000 rpm
Max flow	:	800 gpm
Inlet connection	:	4" 150 / 4" Weco
Outlet Connection	:	3" 150 / 4" Weco
DIMENSIONS		
Height	:	1680 mm
Width	:	1310 mm
Length	:	2700 mm
Weight	:	2500 Kg
CERTIFICATION	:	OMCA MEC I ZONE II SI 1998 No 2307 BS7072 lifting certification

All specifications correct at time of printing, but may be altered subsequently by the company

Buchan Technical Services Limited,
 Unit 7, Fisher Offshore Base, North Meadows,
 Oldmeldrum, Aberdeenshire, Scotland. AB51 0GQ
 Tel: +44 (0) 1651 871450 Fax: +44 (0) 1651 871459
info@buchantechnical.co.uk www.buchantechnical.co.uk
 Member of James Fisher and Sons plc

Registered in Scotland No. 177590- Registered Office North Meadows, Oldmeldrum, Aberdeenshire. AB51 0GQ





RIGSAFE DIESEL DRIVEN CENTRIFUGAL PUMP SET

<u>ENGINE TYPE</u>	:	DETROIT 8VA 71.N
Fuel Type	:	Diesel
Maximum R.P.M.	:	2300
Starting System	:	Air Motor
Clutch Type	:	Anderton Overcentre Twin Plate
H.P.	:	240 @ 1800 R.P.M.
Full Tank Capacity	:	140 Imp. Gal
<u>PUMP TYPE</u>	:	Ingersol Dresser Single Stage, n Stainless steel
Duty	:	291m/hour, 77.6m head
Inlet Connection	:	8" # 300 RF
Outlet Connection	:	6" # 300 RF
<u>DIMENSIONS</u>		
Height	:	7' 7"
Length	:	11' 6"
Width	:	5' 8"
Weight	:	6 Tons
Identification No.	:	W.P.11

All specifications correct at time of printing, but may be altered subsequently by the company

Buchan Technical Services Limited,
Unit 7, Fisher Offshore Base, North Meadows,
Oldmeldrum, Aberdeenshire, Scotland. AB51 0GQ
Tel: +44 (0) 1651 871450 Fax: +44 (0) 1651 871459
info@buchantechnical.co.uk www.buchantechnical.co.uk
Member of James Fisher and Sons plc

Registered in Scotland No. 177590- Registered Office North Meadows, Oldmeldrum, Aberdeenshire. AB51 0GQ



HYDRAULIC DRIVEN SKID MOUNTED CENTRIFUGAL PUMP



Equipment Identity No.	:	W.P.41			
HYDRAULICS					
Max pressure	:	2900 PSI			
Max flow	:	90 Litre/min			
PUMP TYPE					
	:	4" x 3"x 11" single stage			
Max pressure	:	8.5 bar			
Max flow	:	750 gpm			
Inlet connection	:	4" 150 / 4" Weco			
Outlet Connection	:	3" 150 / 4" Weco			
DIMENSIONS					
Height	:	1000 mm	Length	:	1500 mm
Width	:	800 mm	Weight	:	700 Kg
CERTIFICATION	:	SI 1998 No 2307			
		BS7072 lifting certification			

All specifications correct at time of printing, but may be altered subsequently by the company

Buchan Technical Services Limited,
 Unit 7, Fisher Offshore Base, North Meadows,
 Oldmeldrum, Aberdeenshire, Scotland. AB51 0GQ
 Tel: +44 (0) 1651 871450 Fax: +44 (0) 1651 871459
info@buchantechnical.co.uk www.buchantechnical.co.uk
 Member of James Fisher and Sons plc

Registered in Scotland No. 177590- Registered Office North Meadows, Oldmeldrum, Aberdeenshire. AB51 0GQ



ZONE II HYDRAULIC POWER PACK



Equipment Identity No.	:		H.P.P.25
ENGINE TYPE	:		DETROIT 4-71
Fuel Type	:		Diesel
Maximum R.P.M.	:		2000
Engine Horsepower	:		150
Starting System	:		Air Motor
Transmission	:		Direct Drive
Fuel Tank Capacity	:		50 Gallons
PUMP TYPE	:		Open Loop Pressure Compensated Piston Pump (DENNISON) C/w in line oil cooler
Max Pressure	:		6,000 psi
Max Flow/Rev	:		140cc (280 l/min)
Duty	:		200 lpm at 3,000 psi
Hydraulic Oil Tank Capacity	:		210 Litres
CONTROLS	:		350 BAR Flow Meter, 345 BAR variable pressure relief valve, Max Pump volume stop adjustment
Connections	:		1 1/2" BSP supply and return 3/4" BSP Case Drain
DIMENSIONS			
Height	:	2070mm	Length : 2410mm
Width	:	1700mm	Weight : 4000kg
CERTIFICATION			BS 7072 OCMA MEC1 ZONE II

All specifications correct at time of printing, but may be altered subsequently by the company

Buchan Technical Services Limited,
 Unit 7, Fisher Offshore Base, North Meadows,
 Oldmeldrum, Aberdeenshire, Scotland. AB51 0GQ
 Tel: +44 (0) 1651 871450 Fax: +44 (0) 1651 871459
info@buchantechnical.co.uk www.buchantechnical.co.uk
 Member of James Fisher and Sons plc

Registered in Scotland No. 177590- Registered Office North Meadows, Oldmeldrum, Aberdeenshire. AB51 0GQ



DIVER/ROV OPERATED HIGH PRESSURE WATER JETTING SPREAD



PACKAGE INCLUDES

1 Off	:	150HP Zone 2 specification High Pressure Water Jetting Unit (15gpm @ 12000 psi)
1 Off	:	Air Powered Hose Reel
1 Off	:	Reactionless Diver Operated High Pressure Jetting Gun - Dump Type
15 Off	:	20m lengths of 15,000 psi water blast hose
4 Off	:	5m lengths of 15,000 psi water blast hose
1 Off	:	Munro Rotating Jet
1 Off	:	15,000 psi Rotating Swivel
1 Off	:	Spares package for all of above

All specifications correct at time of printing, but may be altered subsequently by the company

Buchan Technical Services Limited,
 Unit 7, Fisher Offshore Base, North Meadows,
 Oldmeldrum, Aberdeenshire, Scotland. AB51 0GQ
 Tel: +44 (0) 1651 871450 Fax: +44 (0) 1651 871459
info@buchantechnical.co.uk www.buchantechnical.co.uk
 Member of James Fisher and Sons plc

Registered in Scotland No. 177590- Registered Office North Meadows, Oldmeldrum, Aberdeenshire. AB51 0GQ



TEMPORARY / CONTRACT PERSONNEL SERVICES

Buchan Technical Services Ltd offer support to oil and gas service companies global operations through the provision of competent, certified and experienced operators, supervisors and engineers across a wide range of disciplines.



We have developed and maintained strong client relationships by successfully understanding and delivering appropriate solutions for flexible working requirements.

OFFSHORE DISCIPLINES PROVIDED

Pipeline Commissioning and Testing
Nitrogen / Helium Leak Detection
Nitrogen Pumping
Fluid Pumping
Coiled Tubing
Bolt Tensioning
Subsea Excavation
Umbilical Testing

Well Intervention Operations
Subsea Deployment / Recoveries
Sand Control
Hydraulics
Filtration
Chemical Injection
Dredging
Labour

Buchan Technical Services Limited,
Unit 7, Fisher Offshore Base, North Meadows,
Oldmeldrum, Aberdeenshire, Scotland. AB51 0GQ
Tel: +44 (0) 1651 871450 Fax: +44 (0) 1651 871459
info@buchantechnical.co.uk www.buchantechnical.co.uk
Member of James Fisher and Sons plc
Registered in Scotland No. 177590- Registered Office North Meadows, Oldmeldrum, Aberdeenshire. AB51 0GQ



INDUCTION PROCESS

On registration with Buchan Technical Services all ad-hoc personnel must complete our OPITO Standard Employing Company Induction, Manual Handling, Risk Assessment etc., and pre-employment drug screen, supply up to date copies of all offshore certification and names of two valid referees.

The personnel department obtains references for new employees either in writing or verbally and these are held on file.

SUBSTANCE ABUSE POLICY

Buchan Technical Services Ltd operates a stringent substance abuse policy. Personnel are required to undertake a drug screen prior to being offered their first assignment with us. Personnel are then subject to random drug screening as determined by Buchan Technical Services Ltd or our clients.

CONTINUOUS ASSESSMENT PROGRAM

We operate a continuous assessment program on a job by job basis with all on and offshore personnel utilising our post-job appraisal form. This form is completed by our on-site client to assess attitudes towards work, environmental and health and safety issues, operation of equipment, quality of work, adaptability/flexibility, initiative, work under pressure, perseverance/determination, team work and problem analysis. The results of which determine employee suitability for future contracts and identify any training required.

Prospective clients can at any time request copies of employee appraisals during the selection process.

CERTIFICATION

We maintain up to date CV's and offshore certification for all personnel, allowing immediate mobilisations to our clients work sites, vessels, offshore installations or overseas locations.

Copies of individuals offshore certificates can be forwarded to clients for their records.

Each time an assignment is completed the information obtained on the Post-Job Appraisal is then transferred onto the individuals CV.

TRAINING

Ad-hoc personnel are also offered a range of theoretical and practical training courses at the Company base in Inverurie, utilising the equipment rental fleet to enhance and maintain their capabilities. Familiarisation training on the use of flooding, well service, pressurisation and other pumping systems together with basic maintenance and use of air powered hose reels has recently been introduced.

Buchan Technical Services Limited,
Unit 7, Fisher Offshore Base, North Meadows,
Oldmeldrum, Aberdeenshire, Scotland. AB51 0GQ
Tel: +44 (0) 1651 871450 Fax: +44 (0) 1651 871459
info@buchantechnical.co.uk www.buchantechnical.co.uk
Member of James Fisher and Sons plc

Registered in Scotland No. 177590- Registered Office North Meadows, Oldmeldrum, Aberdeenshire. AB51 0GQ



LOCATIONS

Personnel registered with Buchan Technical Services Ltd are available for work in any location dependant on valid certification at the time of any enquiry. We have a very reliable ad-hoc crew and since the development of the personnel division contract employees have been deployed in various locations, for a range of different clients, including the North Sea, Europe, Middle East, West Africa and South America. Previous assignments have ranged from one day to six months and all core crew personnel are exceptionally flexible and able to mobilise for assignments at very short notice.

SAFETY EQUIPMENT

Before any assignment is undertaken employees are supplied with full personal protective equipment which consists of, fire retardant coveralls, storm jacket, safety boots, hard hat, and safety glasses, ear defenders and kit bag. BTS ad-hoc personnel wear only plain kit with no Company names or logos. The range of equipment supplied to employees can however be tailored to suit different client requirements, should the need arise.



Buchan Technical Services Limited,
Unit 7, Fisher Offshore Base, North Meadows,
Oldmeldrum, Aberdeenshire, Scotland. AB51 0GQ
Tel: +44 (0) 1651 871450 Fax: +44 (0) 1651 871459
info@buchantechnical.co.uk www.buchantechnical.co.uk
Member of James Fisher and Sons plc

Registered in Scotland No. 177590- Registered Office North Meadows, Oldmeldrum, Aberdeenshire. AB51 0GQ



JOE BLOGGS

POSITION:

OFFSHORE PIPELINE SUPERVISOR

DATE OF BIRTH:

01.01.60

NATIONALITY:

BRITISH

QUALIFICATIONS:

Glasgow Caledonian University, Glasgow
MSc Information Technology
BSc Psychology

TRAINING:

Rotech Subsea Limited Excavation Supervisor Training Course
STATS (UK) Ltd Hydrostatic Testing Course
Conoco Permit To Work Course
Elf Induction Course
BP MAPS
Texaco Induction & Permit To Work Course
Baker Hughes Induction Course
Multifabs Air Pocket Dry Trainer User Course
Chevron Induction Course
Chevron Permit to Work Certificate – Level 2
Kerr McGee Induction & Permit To Work Course
Shell MAPS
Shell PICWS
Specialist Tools And Testing Services (STATS) Ltd Induction
Copipe Systems Limited (PSL) Induction
Buchan Technical Services Ltd In-house Training;
Basic Pipeline Commissioning & Testing Course
Basic Fluid Pumping Course
Basic Zone II Diesel Engines Operation & Maintenance Course
Buchan Technical Services Ltd Employing Company Induction
(OPITO Standard)
Hydratight Bolt Tensioning Course

OFFSHORE CERTIFICATION:

Basic Offshore Safety Induction & Emergency Training Course
European Module including Norwegian Induction Course
UKOOA Medical Certificate
Norwegian Medical Certificate
Yellow Fever Certificate
Vaccinated for travel to all parts of Africa.

Buchan Technical Services Limited,
Unit 7, Fisher Offshore Base, North Meadows,
Oldmeldrum, Aberdeenshire, Scotland. AB51 0GQ
Tel: +44 (0) 1651 871450 Fax: +44 (0) 1651 871459
info@buchantechnical.co.uk www.buchantechnical.co.uk
Member of James Fisher and Sons plc

Registered in Scotland No. 177590- Registered Office North Meadows, Oldmeldrum, Aberdeenshire. AB51 0GQ



EMPLOYMENT HISTORY

Date → present

BUCHAN TECHNICAL SERVICES LTD

OFFSHORE PIPELINE OPERATOR/SUPERVISOR

Position: Offshore Operator
Location: Claymore Platform
Duties: Leak Testing Riser Pipeline using Diesel & Air Driven Pumps

Position: Offshore Senior Operator
Location: Offshore Egypt – Highland Rover
Duties: Lift Pumps, Filtration Units (Hydac), Centrifugal Pumps, Positive displacement pumps, chemical injection pumps & instrumentation package

Position: Offshore Supervisor
Location: Normand Cutter – Italy
Duties: 150 tonne Abandonment & recovery winch powered by 6 Cylinder Cummins Diesel HPU. 35 Tonne recovery winch powered by Electric HPU. Recover 2 ½ + 6 Umbilicals & Risers

Position: Offshore Supervisor
Location: Angola, West Africa
Duties: Pipeline pigging, hydrotesting and de-watering. Operation of centrifugal and pressurising pumps. Pressure testing various umbilicals. Strip down and re-build of equipment.

Position: Offshore Supervisor
Location: Italy – Ana Vesna
Duties: Pigged 6” Gas Pipeline, 3” Oil/Water Pipeline & 2” Air pipeline

Position: Offshore Supervisor
Location: Congo, Africa
Duties: Leak / Barrier Testing

Position: Offshore Supervisor
Location: Tombua Landana, Luanda
Duties: Pressure Testing

Position: Offshore Supervisor
Location: Angola, West Africa
Duties: Rigging up of flooding equipment. Use of flooding pumps & chemical spread

Buchan Technical Services Limited,
Unit 7, Fisher Offshore Base, North Meadows,
Oldmeldrum, Aberdeenshire, Scotland. AB51 0GQ
Tel: +44 (0) 1651 871450 Fax: +44 (0) 1651 871459
info@buchantechnical.co.uk www.buchantechnical.co.uk
Member of James Fisher and Sons plc

Registered in Scotland No. 177590- Registered Office North Meadows, Oldmeldrum, Aberdeenshire. AB51 0GQ



Position: Offshore Supervisor
Location: Mainland Spain
Duties: Rigging Up Equipment for Onshore Pipeline

Position: Onshore Project Manager
Location: Falklands Islands
Duties: Working with MOD

Position: Onshore Supervisor
Location: Angola, West Africa
Duties: Supervising pipeline pressure testing operations

Position: Onshore Supervisor
Location: Sakhalin, Russia
Duties: Pipeline pigging and pressure testing 2 x 8" flowlines. Operation of zone II and rigsafe diesel driven water pumps

Position: Offshore Supervisor
Location: New Zealand
Duties: Pipeline testing, operating centrifugal pumps and air hose reels.

Position: Offshore Operator
Location: Angola
Duties: Operation of centrifugal and pressurising pumps. Pressure testing various umbilicals. Strip down and re-build of equipment.

Position: Offshore Supervisor
Location: Kingfisher Vessel, Gulf of Mexico
Duties: Subsea Excavation operations

Position: Offshore Supervisor
Location: Gryphon
Duties: Pipeline Pressure Testing

Position: Offshore Supervisor
Location: Bonga FPSO
Duties: Flushing, Testing & Pigging

Buchan Technical Services Limited,
Unit 7, Fisher Offshore Base, North Meadows,
Oldmeldrum, Aberdeenshire, Scotland. AB51 0GQ
Tel: +44 (0) 1651 871450 Fax: +44 (0) 1651 871459
info@buchantechnical.co.uk www.buchantechnical.co.uk
Member of James Fisher and Sons plc

Registered in Scotland No. 177590- Registered Office North Meadows, Oldmeldrum, Aberdeenshire. AB51 0GQ

